

For additional information or copies of your service manual, please visit us online at:

binks.com/en/library

Or use this QR code with your mobile device:

83C PRESSURE TANK



Obey local or municipal regulations for product recycling and disposal.

02 CONTENTS

03 SAFETY	1-4
03.1 SAFETY PRECAUTIONS.....	1
03.2 ADDITIONAL SAFETY INFORMATION	4
04 PRODUCT OVERVIEW	5
04.1 GENERAL SPECIFICATIONS.....	5
04.2 DESCRIPTION	5
04.3 MODELS	5
05 INSTALLATION & OPERATION	7-9
05.1 PRESSURE RELIEF STEPS	7
05.2 PT-418 AIR DRIVEN AGITATOR.....	7
05.3 AIR MOTOR ASSEMBLY.....	7
05.4 REPLACEMENT OF PARTS: AIR MOTOR ASSEMBLY.....	7
05.5 INSTALLATION	8
05.6 OPERATION.....	8
06 PARTS IDENTIFICATION	10-14
06.1 83C-2XX TANK ASSEMBLIES	10
06.2 AIR MOTOR/ADAPTOR ASSEMBLY	12
06.3 HAR-507 & HAR-511 REGULATOR ASSEMBLIES	14
07 MAINTENANCE	15
07.1 CLEANING PROCEDURE	15
07.2 SERVICE CHECKS.....	15
08 ACCESSORIES	16
09 MANUAL REVISIONS	17
10 WARRANTY	19

This page intentionally left blank.

03 SAFETY

03.1 SAFETY PRECAUTIONS

Before the operation, maintenance, or servicing of this Binks system; fully read and understand all technical and safety literature for your product. This manual contains information that is important for you to know and understand.

This information relates to **USER SAFETY** and the **PREVENTION OF EQUIPMENT PROBLEMS**.

To help you understand this information, we use recognizable ANSI Z535 and ISO warning boxes and symbols throughout this manual. Please obey these safety sections.

⚠ DANGER

DANGER!: Indicates a hazardous situation that, if not avoided, will result in death or severe injury.

⚠ WARNING

WARNING!: Indicates a hazardous situation that, if not avoided, could result in death or severe injury.

⚠ CAUTION

Caution!: Indicates a hazardous situation that, if not avoided, could result in minor or moderate injury, or equipment damage.

NOTICE

Notice: Indicates information considered important but not hazard related.

SAFETY

Safety: Indicates a type of safety instruction, or a separate panel on a safety placard, where specific safety-related instructions or procedures are described.

Careful study and continued use of this manual will provide a better understanding of the equipment functions and procedures.

This understanding will result in improved operation, efficiency, and longer, trouble-free service with faster and easier troubleshooting. If you need the necessary safety literature for your specific system, contact your local Binks representative or Binks directly.

NOTICE

This manual lists standard specifications and service procedures. Differences can occur between this literature and your equipment.

Differences in local or municipal codes, manufacturer or plant requirements, material delivery requirements, and more can make variations unpreventable. To find these differences, compare this manual to your system installation drawings and other applicable Binks equipment manuals.

⚠ WARNING

The user **MUST** read and be familiar with the Safety Section in this manual and the safety literature therein identified.

Only trained personnel can operate this equipment.





All personnel who operate, clean, or maintain this equipment **MUST** fully read and understand this manual! To operate and service the equipment, follow all **WARNINGS** and safety requirements.

The user must be aware of and adhere to **ALL** local building and fire codes and ordinances, as well as **NFPA 33 AND EN 16985 SAFETY STANDARDS, LATEST EDITION**, or applicable country safety standards, before the installation, operation, or servicing of this equipment.

⚠ WARNING

The hazards shown on the pages that follow can occur during the normal use of this Binks equipment, but not all listed hazards will be applicable to your product model or equipment.

Repairs may only be performed by personnel authorized by Binks.

HAZARD	CAUSE	SAFEGUARDS Prevention of possible hazards.
<p>Fire</p> 	<p>Solvent and coatings can be highly flammable or combustible especially when sprayed.</p>	<ol style="list-style-type: none"> 1. Adequate exhaust must be provided to keep air free of accumulations of flammable vapours. 2. Smoking must never be allowed in the spray area. 3. Fire extinguishing equipment must be present in the spray area.
<p>Fire – Pressure Tank</p> 	<p>Vapors from flammable liquids can catch fire or explode.</p>	<p>Keep tank at least 10 feet away from sources of ignition. Ignition sources include hot objects, mechanical sparks, and arcing (non-explosion proof) electrical equipment.</p>
<p>Inhaling Toxic Substances</p> 	<p>Certain materials may be harmful if inhaled, or if there is contact with the skin.</p>	<ol style="list-style-type: none"> 1. Follow the requirements of the Safety Data Sheet supplied by your coating material manufacturer. 2. Adequate exhaust must be provided to keep the air free of accumulations of toxic materials. 3. Use a mask or respirator whenever there is a chance of inhaling sprayed materials. The mask must be compatible with the material being sprayed and its concentration. Equipment must be as prescribed by an industrial hygienist or safety expert, and be NIOSH approved.
<p>Explosion, Pressure Tank – Rupture</p> 	<p>tank will weaken it.</p>	<ol style="list-style-type: none"> 1. Never drill into, weld, or modify tank in any way. 2. Do not adjust, remove, or tamper with the safety valve. If replacement is necessary, use the same type and rating of valve.

HAZARD	CAUSE	SAFEGUARDS Prevention of possible hazards.
General Safety	Improper operation or maintenance of equipment.	Operators should be given adequate training in the safe use and maintenance of the equipment (in accordance with the requirements of NFPA-33, Chapter 15). Users must comply with all local and national codes of practice and insurance company requirements governing ventilation, fire precautions, operation, maintenance, and housekeeping. These are OSHA Sections 1910.94 and 1910.107 and NFPA-33.

03.2 ADDITIONAL SAFETY INFORMATION

Observe all local or municipal safety measures and wear approved protective equipment when servicing this equipment. Clean all spilled chemicals and materials and do all work in a clean and organized environment to prevent personal injury and equipment damage.

04.1 GENERAL SPECIFICATIONS

83C PRESSURE FEED TANK ASSEMBLIES				
Maximum Working Pressure	5.5 bar [80 PSI]			
Safety Valve Set Pressure	5.5 bar [80 PSI]			
Tank Shell	Zinc plated carbon steel			
Tank Lid	Zinc plated carbon steel			
Lid Gasket	Sarlink			
Fluid Tube	Zinc plated carbon steel			
Fluid Outlet	Zinc plated carbon steel			
Fluid Outlet Size	3/8" NPS (M)			
Air Manifold	CRS Zinc Plated			
Air Inlet Size	1/4" NPS (M)			
Air Motor Air Consumption	85-170 liters/min (3-6 CFM) at 4.1 bar (60psi)			
Maximum Agitator Pressure	6.7 bar (100 psi)			
Tank Capacity	2.76 US Gallons			
Tank Height	9-9/16", (10-1/2" to top of lid)			
Tank Weight	83C-210: 28-1/4 lbs.	83C-220: 29-3/4 lbs.	83C-211: 32-3/4 lbs.	83C-221: 34-1/4 lbs.

04.2 DESCRIPTION

NOTICE

The 83C pressure tanks are designed as a pressure container to supply liquid material at a constant preset pressure up to a maximum of 80 PSI. The tanks are built to ASME specifications. All models include a polyethylene liner. All models are for light to medium duty use only.

04.3 MODELS

83C-210: Single regulation (fluid), air inlet/outlet, fluid outlet, safety valve.

83C-220: Dual regulation (air and fluid), air inlet/outlet, fluid outlet, safety valve.

83C-211: Single regulation (fluid), air driven agitator assembly, fluid outlet, safety valve.

83C-221: Dual regulation (air and fluid), air driven agitator assembly, fluid outlet, safety valve.

This page intentionally left blank.

⚠ WARNING

High air pressure loads that are higher than design loads, or changes to the pressure feed tank can cause the tank to rupture or explode.

⚠ WARNING

A safety valve protects the tank from over pressurization. During each use pull the ring on the safety valve to make sure it operates freely and relieves air pressure. If the valve is stuck, does not operate freely, or does not relieve air pressure, it must be replaced. Do not eliminate, make adjustments or substitutions to this valve.

⚠ WARNING

Changes to the air tank will weaken it. Never drill into, weld or change the tank in any way.

⚠ WARNING

High pressure can cause serious injury. Pressure is maintained in a pressure tank after the system has been shut down. Before attempting removal of the cover, pressure must be relieved using the steps below.

05.1 PRESSURE RELIEF STEPS

1. Turn off the main air supply to the tank.
2. Close air inlet valve located on the tank air manifold.
3. Bleed off air in the tank by turning the air relief valve thumb screw counterclockwise. Wait until all the air has escaped through the valve before removing the pressure tank cover.
4. Leave the air relief valve open until you have reinstalled the cover.

05.2 PT-418 AIR DRIVEN AGITATOR

- The agitator utilizes an air driven motor to turn the agitator shaft to which a propeller is attached.
- The rotation of the propeller mixes materials which have a tendency to separate or settle quickly.
- Material agitation may be performed at the same time material is being sprayed without any adverse effect.
- The air motor is powerful and smooth running.
- An air adjusting valve is included to control the speed of the agitator.
- The air motor requires low air consumption, approximately 3-6 C.F.M. at 60 psi (Max. input air pressure 100 psi.)

⚠ CAUTION

If using an air quick disconnect (Q.D.) at the inlet to the regulator at the pressure tank, do not disconnect the Q.D. while the tank is pressurized, unless the ball valve is closed. Doing so will allow tank pressure to quickly relieve, and can potentially pull paint back through the air regulator and air motor, depending upon the liquid level in the tank. Tank pressure should always be relieved by turning the regulator fully counterclockwise, or pulling the safety valve ring.

05.3 AIR MOTOR ASSEMBLY**⚠ CAUTION**

Failure to properly lubricate the air motor will result in premature motor failure and will void warranty.

⚠ CAUTION

Lubricate air motor daily by adding 4 or 5 drops of SAE 10 weight oil into air inlet fitting.

NOTICE

Clean the agitator shaft (54) and the propeller (56) at the end of each day.

NOTICE

Occasionally remove and clean the muffler strainer felt (60) or replace, if necessary.

05.4 REPLACEMENT OF PARTS: AIR MOTOR ASSEMBLY

- Do not pry front plate (40) or end plate (46) from air motor body (43) with a screwdriver; this will dent the surface of the plates and body causing leaks.
- A puller tool should be used to remove the plate from the motor body while maintaining the position of the shaft.
- Holes must be drilled for dowel pins (42) after assembling front plate (40) on new body (43) for alignment of parts.
- Always install new endplate gaskets (41) when re-assembling air motor.

05.5 INSTALLATION

Mix and prepare material to be used according to manufacturer's instructions. Strain material through a fine mesh screen (60 or 90 mesh) to remove all foreign matter which is likely to enter and clog material passages.

1. Always relieve all air pressure in the tank. Pull the ring on the safety valve until pressure bleeds down.
2. Loosen thumb screws, tip lid clamps back and remove lid assembly.
3. Pour material into the tank. See accessories for disposable tank liners. A one-gallon container may also be used by cutting 5 mm off end of fluid tube at an angle.
4. Replace the lid assembly, tighten clamps, and thumb screws securely.

NOTICE

Tighten down C-clamps to 11 – 13.6 Nm (8-10 ft-lbs) or turn thumb screws approximately 1/2 to 1 turn past hand tight in a cross pattern.

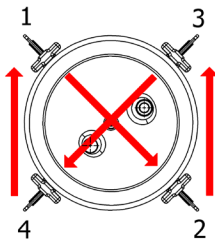

5. If possible, the air supply line should pass through an air filter/regulator to filter dirt from air and remove entrained water and oil. See the accessories section for filters available. Connect the air supply hose to the air inlet fitting on tank regulator.
6. Connect the atomization air hose to the air outlet fitting which is directly opposite air inlet fitting.
7. Connect material hose to the fluid outlet fitting.
8. See Figure 1 below for a typical set-up.

05.6 OPERATION

1. Turn on the air supply.
2. Turn T-Handle adjusting screw clockwise on the tank regulator to increase material pressure: turn it counterclockwise to decrease pressure. Maximum tank pressure is 80 psi.
3. For tank with air motor agitator, turn the knob of the air adjusting valve (8) counterclockwise to set the desired agitator speed. Operate the agitator at the minimum speed required to keep the material thoroughly mixed. Do not over-agitate the material. Air bubbles may form in the material, causing a poor finish.
4. Atomization air for the spray gun can be adjusted at the gun by means of an air adjusting valve (P-H-5516) or, with the additional air regulator provided with "dual regulation" tank models (83C-220 or 83C-221).
5. See Spray Gun instructions for operation of the gun.

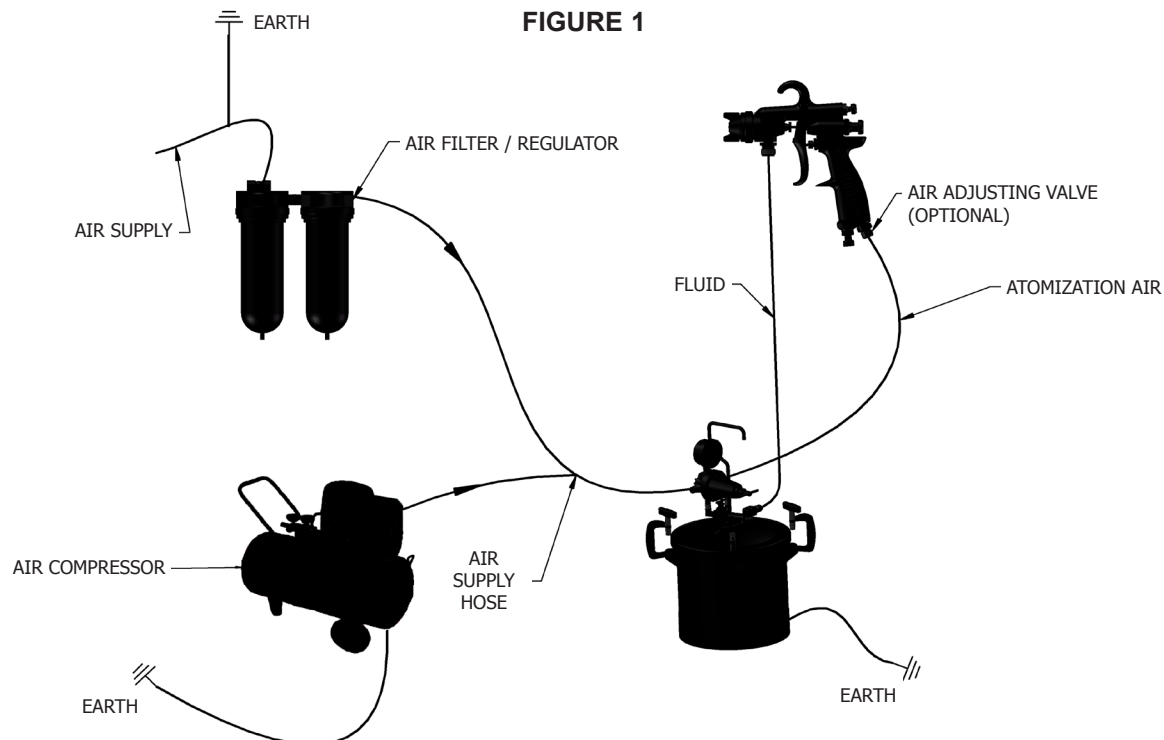

NOTICE

Air regulators are shipped unassembled to prevent shipping damage. As a result, some assembly is required.

1. Assemble the handle into the tank and secure with a 9/16 wrench as shown in Figure 2.

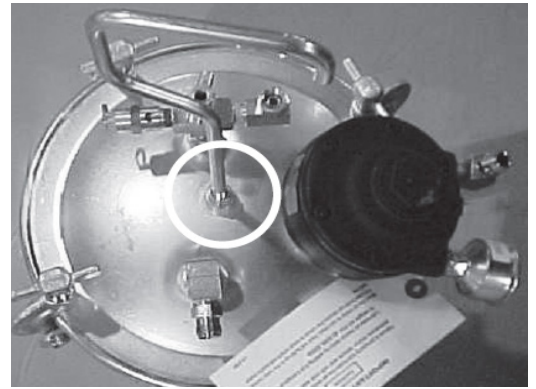

Figure 2

2. Assemble either the single or double regulator to the manifold with a 11/16 wrench as shown in Figure 3.

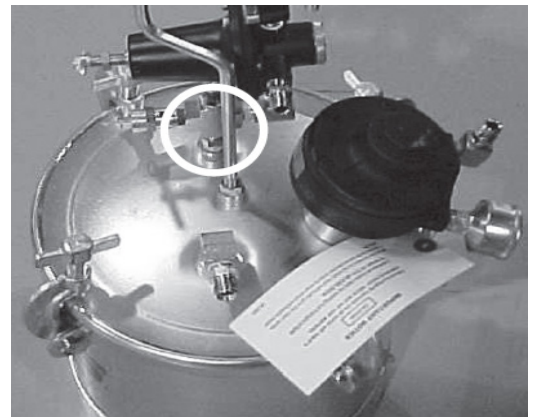

Figure 3

3. Assemble the valve end of the hose assembly to the regulator using a 5/8 wrench. Assemble the other end of hose to the air motor with the same wrench as shown in Figure 4.

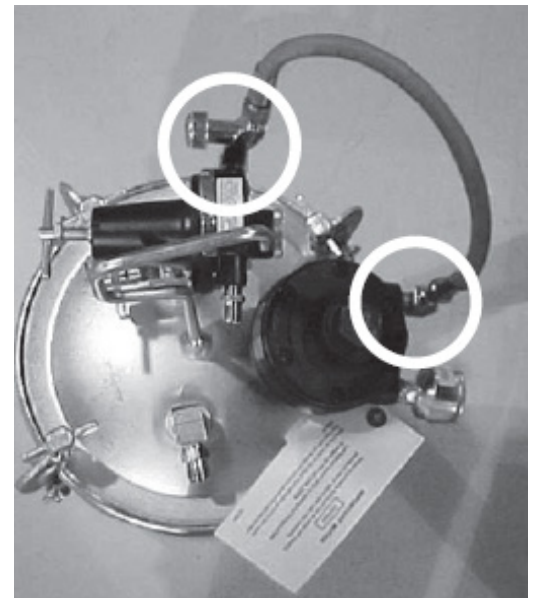
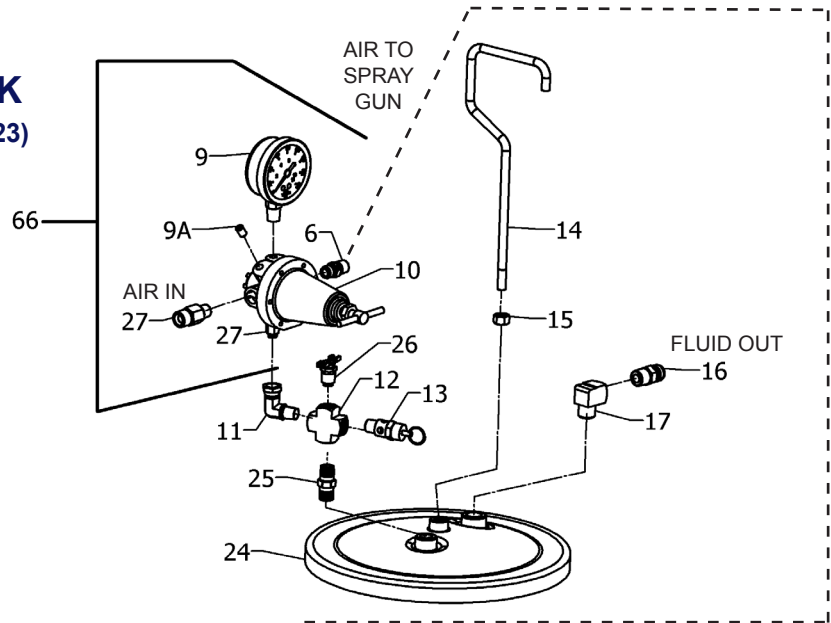

Figure 4

06.1 83C-2XX TANK ASSEMBLIES

83C-210 PRESSURE TANK

(Includes Item No. 1, 2 and 18 thru 23)



83C-220 & 83C-221 PRESSURE TANK

(Dual regulation included with these models)

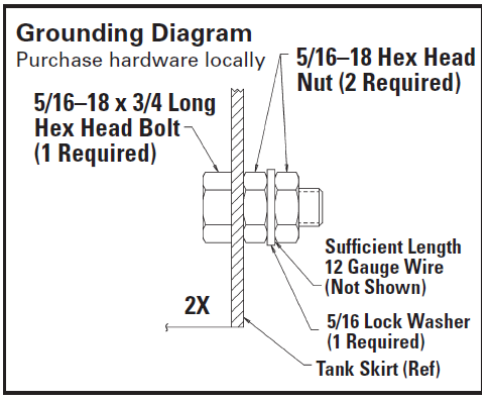
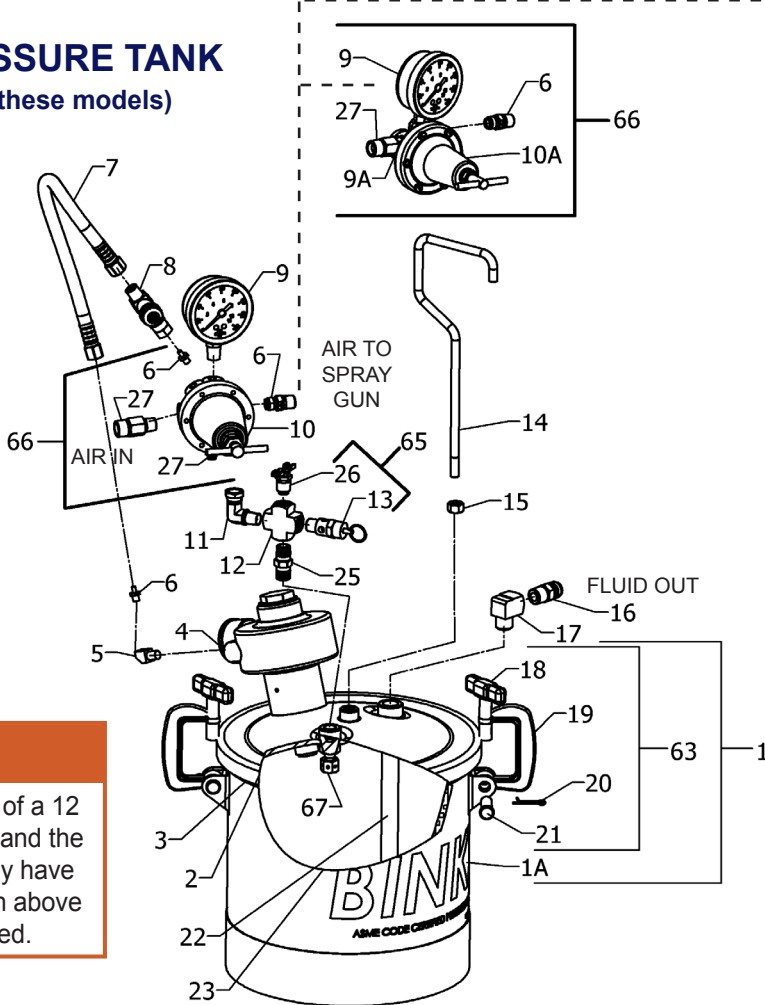

! WARNING

Ground the pressure tank by connecting one end of a 12 gauge minimum ground wire to the pressure tank and the other end to a true earth ground. Local codes may have additional grounding requirements. See illustration above for grounding and grounding hardware required.

83C-211 PRESSURE TANK WITH AGITATOR

83C-2XX TANK ASSEMBLY PARTS LIST

Item No.	Part No.	Description	Qty.	Notes
1	PT-423	Tank Assy. Kit (Includes Numbers 1A, 18, 19, 20 & 21)	1	
1A	PT-420	Tank Shell	1	
2	PT-33-1	Lid Gasket	1	
3	PT-425	Lid, Zinc Plated (Agitator)	1	
4	PT-418	Air Motor/Adaptor Assembly (See page 18 for breakdown)	1	
5	-	Street Elbow 1/4" NPT (F) x 1/4" NPT (M)	1	
6	H-2008	Nipple 1/4" NPT(M) x 1/4" NPS(M) (83C-210 & 83C-220)	2	▪
		Nipple 1/4" NPT(M) x 1/4" NPS(M) (83C-211 & 83C-221)	3	
7	HA-57011	Hose Assembly	1	
8	HAV-500	Air Adjusting Valve 1/4" NPS (F) x 1/4" NPS (M)	1	
9	83-2727	Gauge (83C-210, 83C-211)	1	▪
		Gauge (83C-220, 83C-221)	2	
9A	-	Pipe Plug 1/4" NPT(M)(Supplied/Reg)	1	▪
10	HAR-511	Regulator (All regulated models)	1	▪
10A	HAR-507	Regulator (83C-220 & 83C-221)	1	▪
11	SSP-30-ZN	90° Swivel Adaptor 1/4" NPS (F) x 1/4" NPT (M)	1	
12	-	Cross 1/4" NPT (F)	1	
13	TIA-4080	Safety Valve - 80 psi	1	
14	PT-32	Handle	1	
15	-	Hex Nut 3/8" - 16	1	
16	AD-11	Nipple 3/8" NPT (M) x 3/8" NPT (M) S.S.	1	
17	SSP-1939	Street Elbow 3/8" NPT (F) x 3/8" NPT (M) S.S.	1	
18	-	Thumb Screw	4	•
19	-	Yoke Assembly	4	•
20	-	Cotter Pin, 3/32 x 1"	4	•
21	-	Hinge Pin	4	•
22	QMS-9-1	Fluid Tube, Galvanized	1	
23	PT-78-K10 or PT-78-K60	Tank Liner (Kit of 10 or 60)	1	
24	PT-426	Lid, Zinc Plated	1	
25	SSP-462-ZN	Hex Nipple 1/4" NPT (M)	1	
26	SS-2707	Air Relief Valve	1	
27	83-4233	D. M. Nipple (Universal Pipe Thread) (83C-210, 83C-211)	2	▪
		D. M. Nipple (Universal Pipe Thread) (83C-220, 83C-221)	3	
63	KK-5057	Clamp, Pin & Screw Kit (1 each of Numbers 18, 19, 20 & 21)	1	
65	KK-5076	Safety Valve & Drain Valve Kit (1 each of Numbers 13 & 26)	1	
66	85-451	Air Control Assembly for 83C-210	1	
	85-452	Air Control Assembly for 83C-211	1	
	85-453	Air Control Assembly for 83C-220	1	
	85-454	Air Control Assembly for 83C-221	1	
67	41-646	Diffuser	1	

Parts without part numbers listed can be purchased locally.

• KK-5057 Kit contains 1 each of part number 18, 19, 20 & 21.

Suffixes -K2, K5, K10 designate kits of multiple parts.

▪ Items included within Air Control Assembly (Item 66).

06.2 AIR MOTOR/ADAPTOR ASSEMBLY

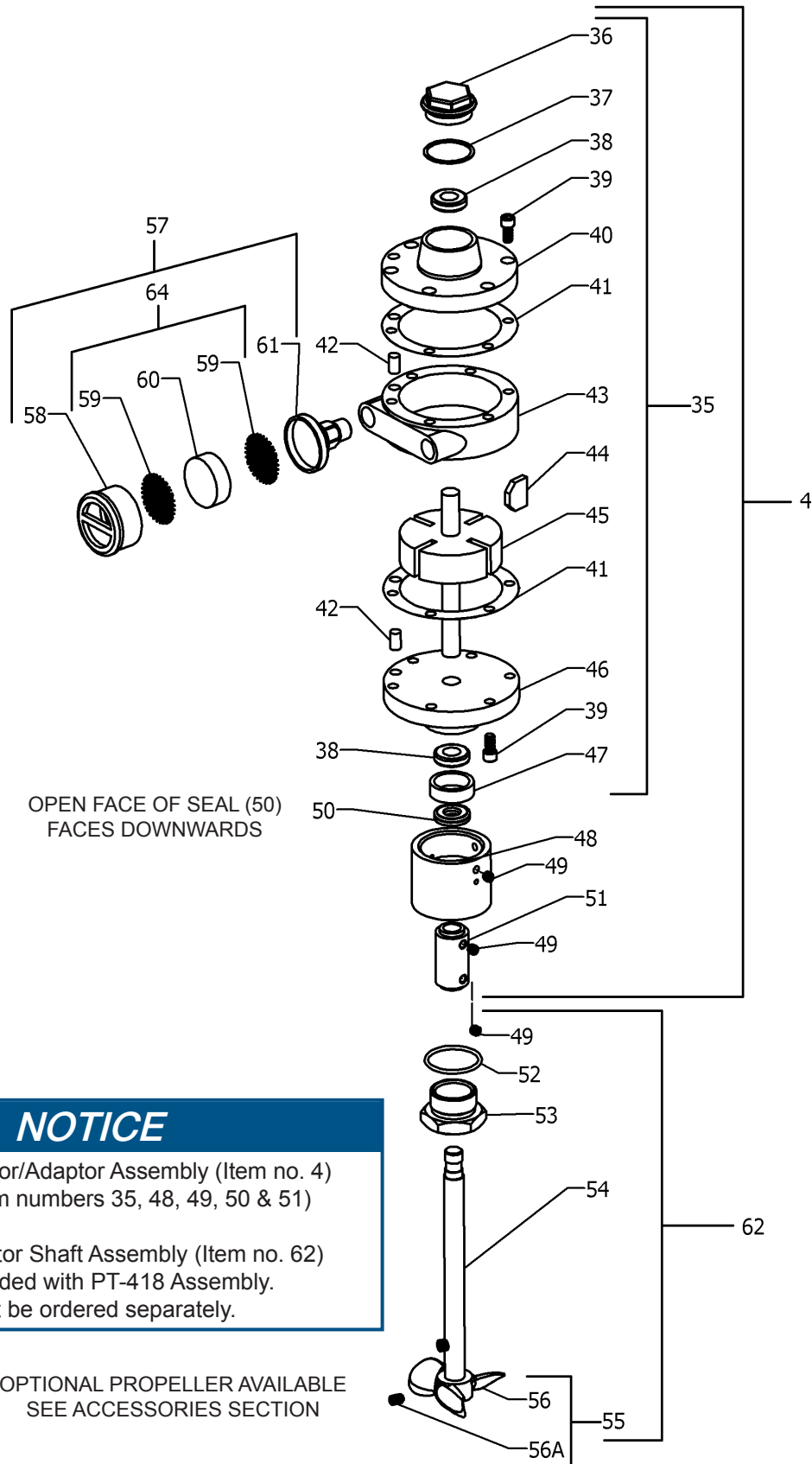

OPEN FACE OF SEAL (50)
FACES DOWNWARDS

NOTICE

PT-418 Air Motor/Adaptor Assembly (Item no. 4)
(Includes item numbers 35, 48, 49, 50 & 51)

PT-428 Agitator Shaft Assembly (Item no. 62)
not included with PT-418 Assembly.
Must be ordered separately.

OPTIONAL PROPELLER AVAILABLE
SEE ACCESSORIES SECTION

AIR MOTOR/ADAPTOR ASSEMBLY PARTS LIST				
Item No.	Part No.	Description	Qty.	Notes
35	PT-410	Air Motor Assembly	1	
36	QS-190	End Cap	1	
37	See Notes	End Cap Gasket	1	*
38	PT-58	Bearing	2	
39	-	Screw (1/4"-28 x 1/2")	12	
40	See Notes	Front Plate	1	
41	PT-59-1-K10	End Plate Spacer	2	*
42	QS-189-1-K10	Dowel Pin (Kit of 10)	4	
43	See Notes	Body	1	
44	See Notes	Vane	4	*
45	See Notes	Rotor Assembly	1	
46	See Notes	End Plate	1	
47	37-90	Shaft Seal	1	
48	PT-50	Air Motor Adaptor	1	□
49	-	Set Screw (1/4"-20 x 1/4")	4	□ •
50	KK-5041	Seal Assembly	1	□
51	QMG-441	Shaft Coupling Kit (Includes no. 49)	1	•
52	SSG-8096-K5	"O" Ring (Kit of 5)	1	□
53	PT-70	Adaptor Nut	1	□
54	QMG-56	Shaft	1	•
55	QMS-448	Propeller Assembly	1	•
56	See Item 55	Propeller	1	
56A	-	Set Screw (1/4"-20 x 3/8" S.S.)	1	
57	350-401	Muffler Assembly	1	
58	See Item 57	Body	1	
59	See Notes	Screen	2	†
60	See Notes	Felt	1	* †
61	See Item 57	Cap	1	
62	PT-428	Agitator Shaft Assembly	1	◇
64	KK-5006	Strainer Screen & Felt Kit (Includes 2 each of Number 59 & 4 each of Number 60)	1	

Parts without part numbers listed can be purchased locally.

* Parts included in KK-5001-1A Air Motor Repair Kit.

□ Parts included in KK-5074 Air Motor Adapter Kit.

• Parts included in KK-5075 Agitator Shaft Assembly Kit.

† Item number (59) 2 each and item number (60) 4 each. Included in KK-5006 strainer screen and felt kit.

◇ PT-428 Agitator Shaft Assembly item number (62) not included with PT-418 Assembly item number (4).

Must be ordered separately.

06.3 HAR-507 & HAR-511 REGULATOR ASSEMBLIES

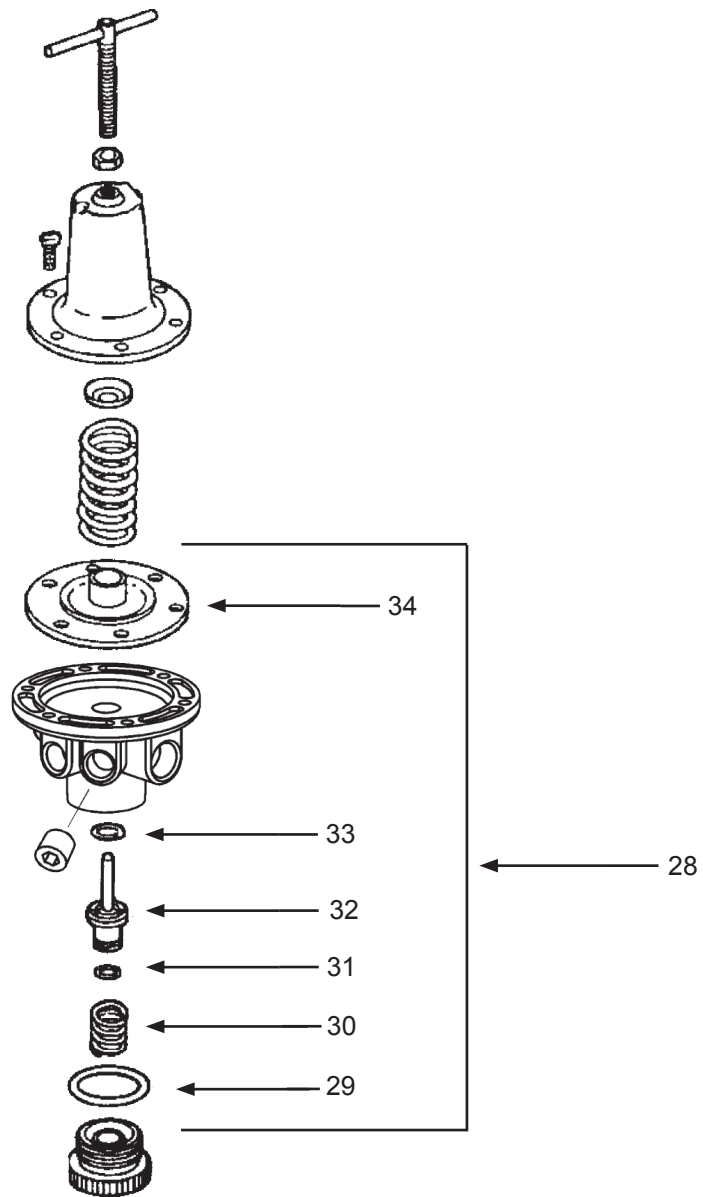

HAR-507 & HAR-511 REGULATOR ASSEMBLIES (HAR-511 shown above)				
Item No.	Part No.	Description	Individual Parts Required	Notes
28	KK-4977	Repair Kit	1	
29	-	"O" Ring	1	+
30	-	Spring	1	+
31	-	"O" Ring	1	+
32	-	Valve	1	+
33	-	"O" Ring	1	+
34	-	Diaphragm Assembly	1	+

+ Included in KK-4977 repair kit

07.1 CLEANING PROCEDURE

1. If tank is equipped with agitator, turn off air to agitator first. This will prevent the possibility of paint contamination of the agitator air motor.
2. Turn off the main air supply to the tank.
3. Turn T-handle adjusting screw on tank regulator counterclockwise until no spring tension is felt.
4. Relieve all pressure from the tank by pulling the ring on the safety valve until the pressure bleeds down.
5. Loosen thumb screws, tip clamps back and tip tank lid to one side.
6. Loosen spray gun air cap retaining ring about three turns.
7. Turn on the air supply to spray gun.
8. Place cloth over air cap on the gun and pull trigger. This will force material back through the hose, into the tank.
9. Empty and clean tank and parts which come in contact with material. Use a suitable cleaning material.
10. Pour cleaning material into the tank.

11. Replace lid and tighten thumb screws and clamps.

NOTICE

Tighten down C-clamps to 11 – 13.6 Nm (8-10 ft-lbs) or turn thumb screws approximately 1/2 to 1 turn past hand tight in a cross pattern.

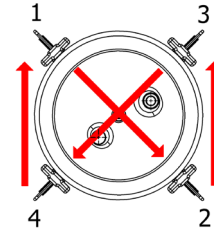

12. Spray until clean solution appears.
13. Repeat steps 5 through 8.

CAUTION

Keep the safety valve clean at all times. Check regularly by pulling the ring to ensure the valve is free to operate.

07.2 SERVICE CHECKS

CONDITION	CAUSE	CORRECTION
Air escaping from port on regulator cap	Broken or damaged diaphragm	Replace diaphragm
Pressure creepage registered on gauge	Dirty or worn valve seat in regulator	Clean or replace valve seat
Fluid or air leak at lid gasket	1. Thumb screw not tight 2. Defective lid gasket	1. Tighten 2. Replace
Air leakage from safety valve below maximum working pressure	The valve seal is dirty or damaged or the valve stem assembly is seized	Replaced safety valve. Do not attempt to repair
Air leakage at agitator seal assembly	Defective seal assembly	Replace
Paint getting into bearing assembly of agitator	1. Paint level in tank too high 2. Defective agitator shaft seal	1. Keep fluid level under bearing assembly 2. Replace
Material tends to settle out rapidly	Not enough agitation of material	Increase agitation
Air mixing with paint	1. Fluid tube not sealed to lid 2. Excessive agitation	1. Tighten fluid tube into lid 2. Reduce speed of agitator
Air motor seized	Damaged seal assembly (Ref. no. 50)	Replace seal
A. If agitator shaft does not turn by hand B. If agitator shaft turns freely, check air motor	Vanes (Ref. no. 44) blackend of chipped at outer edges due to a lack of lubrication	Replace with repair kit KK-50011 and refer to air motor agitator lubrication instructions

NOTICE

Occasionally check gauge (Ref. no. 9). The needle should return to zero with no pressure on the gauge.

PROSPECTOR™ PRESSURE TANK STRAINERS FOR 2 GALLON TANKS

Prospector™ strainers are an economical way to remove foreign material from paint, stain, lacquer and coatings.

Inner Diameter.....8.75" (222.25mm)
 Outer Diameter..... 10.625" (269.87mm)
 Height/Depth.....2.625" (66.67mm)
 Case Qty..... 20

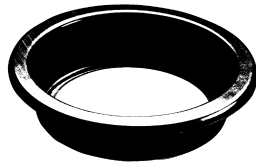

PTS-2Gal-K20-200.....200 micron
 (approx. 65 wire mesh)

PTS-2Gal-K20-400.....400 micron
 (approx. 37 wire mesh)

PTS-2Gal-K20-600.....600 micron
 (approx. 28 wire mesh)

DISPOSABLE TANK LINERS

Single use molded polyethylene tank liners reduce solvent waste and tank cleanup time. The liner is made of tough, durable, leakproof polyethylene and can be used with all compatible materials.

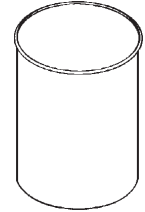

PT-78-K10 Kit of 10 tank liners

PT-78-K60 Kit of 60 tank liners

OPTIONAL PROPELLER QMS-79

Used with light viscosity or waterborne materials where overagitation may be a problem.

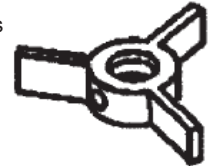

For additional accessory components including other fluid filters, strainers, regulators and valve options, please visit binks.com.

MANUAL CHANGE SUMMARY

Date	Description	Version
08/15/2025	Revised Safety section	R9
05/08/2025	Rebranded to Binks	R8
05/29/2024	Updated to new template AND added tank lid tightening notice	R7

This page intentionally left blank.

WARRANTY POLICY

This product is covered by Binks' materials and workmanship limited warranty.

The use of parts or accessories from sources other than Binks will void all warranties. Failure to follow reasonable maintenance guidance provided can invalidate the warranty.

For specific warranty information, please contact Binks.

For technical assistance or to locate an authorized distributor, contact one of our international sales and customer support locations listed below.

REGION	BINKS CONTACT
Americas	Tel: 1-800-992-4657
Europe, Africa, Middle East	Tel: +4401202571111
India	marketingroa@binks.com
China	Tel: +862133730108
Korea	Tel: +82313663303
Japan	Tel: +81457856421
Australia	Tel: +61085257555

WARRANTY PAGE

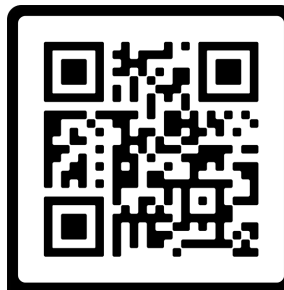

Binks[®]

Binks is a global leader in innovative finishing technologies.
Binks reserves the right to modify equipment specifications without prior notice.
Binks[®], DeVilbiss[®] and Ransburg[®] are registered trademarks of Binks US, LLC.