

For additional information or copies of your service manual, please visit us online at:

binks.com/en/library

Or use this QR code with your mobile device:

83C-210-CE & 83Z-210-CE



Obey local or municipal regulations for product recycling and disposal.

02 CONTENTS

03 SAFETY	1-4
03.1 SAFETY PRECAUTIONS.....	1
03.2 ADDITIONAL SAFETY INFORMATION	4
04 PRODUCT OVERVIEW	5
04.1 GENERAL SPECIFICATIONS.....	5
04.2 DESCRIPTION	5
04.3 CERTIFICATIONS.....	5
04.4 MODELS	5
05 INSTALLATION & OPERATION	6-7
05.1 PRESSURE RELIEF STEPS	6
05.2 INSTALLATION	7
05.3 OPERATION.....	7
06 PARTS IDENTIFICATION	8-10
06.1 83C-210-CE & 83Z-210-CE TANK ASSEMBLIES.....	8
06.2 HAR-511 REGULATOR ASSEMBLIES	10
07 MAINTENANCE	11
07.1 CLEANING PROCEDURE	11
07.2 SERVICE CHECKS.....	11
08 ACCESSORIES	12
09 STATEMENT OF COMPLIANCE	13
10 MANUAL REVISIONS	14
11 WARRANTY	15

This page intentionally left blank.

03 SAFETY

03.1 SAFETY PRECAUTIONS

Before the operation, maintenance, or servicing of this Binks system; fully read and understand all technical and safety literature for your product. This manual contains information that is important for you to know and understand.

This information relates to USER SAFETY and the PREVENTION OF EQUIPMENT PROBLEMS.

To help you understand this information, we use recognizable ANSI Z535 and ISO warning boxes and symbols throughout this manual. Please obey these safety sections.

⚠ DANGER

DANGER! Indicates a hazardous situation that, if not avoided, will result in death or severe injury.

⚠ WARNING

WARNING! Indicates a hazardous situation that, if not avoided, could result in death or severe injury.

⚠ CAUTION

Caution! Indicates a hazardous situation that, if not avoided, could result in minor or moderate injury, or equipment damage.

NOTICE

Notice: Indicates information considered important but not hazard related.

SAFETY

Safety: Indicates a type of safety instruction, or a separate panel on a safety placard, where specific safety-related instructions or procedures are described.

Careful study and continued use of this manual will provide a better understanding of the equipment functions and procedures.

This understanding will result in improved operation, efficiency, and longer, trouble-free service with faster and easier troubleshooting. If you need the necessary safety literature for your specific system, contact your local Binks representative or Binks directly.

NOTICE

This manual lists standard specifications and service procedures. Differences can occur between this literature and your equipment.

Differences in local or municipal codes, manufacturer or plant requirements, material delivery requirements, and more can make variations unpreventable. To find these differences, compare this manual to your system installation drawings and other applicable Binks equipment manuals.

⚠ WARNING

The user **MUST** read and be familiar with the Safety Section in this manual and the safety literature therein identified.

Only trained personnel can operate this equipment.





All personnel who operate, clean, or maintain this equipment **MUST** fully read and understand this manual! To operate and service the equipment, follow all **WARNINGS** and safety requirements.

The user must be aware of and adhere to **ALL** local building and fire codes and ordinances, as well as **NFPA 33 AND EN 16985 SAFETY STANDARDS, LATEST EDITION**, or applicable country safety standards, before the installation, operation, or servicing of this equipment.

⚠ WARNING

The hazards shown on the pages that follow can occur during the normal use of this Binks equipment, but not all listed hazards will be applicable to your product model or equipment.

Repairs may only be performed by personnel authorized by Binks.

HAZARD	CAUSE	SAFEGUARDS Prevention of possible hazards.
<p>Fire</p> 	<p>Solvents and coatings can be highly combustible, especially when sprayed.</p>	<ol style="list-style-type: none"> 1. Adequate exhaust must be provided to keep air free of accumulations of flammable vapours. 2. Smoking must never be allowed in the spray area. 3. Fire extinguishing equipment must be present in the spray area.
<p>Fire – Pressure Tank</p> 	<p>Vapours from flammable liquids can catch fire or explode.</p>	<p>Keep tank at least 3 metres away from sources of ignition. Ignition sources include hot objects, mechanical sparks, and arcing (non-explosion proof) electrical equipment.</p>
<p>Inhaling Toxic Substances</p> 	<p>Certain materials may be harmful if inhaled, or if there is contact with the skin.</p>	<ol style="list-style-type: none"> 1. Follow the requirements of the Safety Data Sheet supplied by your coating material manufacturer. 2. Adequate exhaust must be provided to keep the air free of accumulations of toxic materials. 3. Use a mask or respirator wherever there is a risk of inhaling sprayed materials. The mask must be suitable for the material being sprayed.
<p>Explosion, Pressure Tank – Rupture</p> 	<p>Making any changes or modification to the pressure tank may weaken it.</p>	<ol style="list-style-type: none"> 1. Never drill into, weld or modify the tank in any way. 2. Do not adjust, remove or tamper with the safety valve. 3. Only replace the safety valve with the correct spare part as listed. 4. Do not fit any other safety valve of a higher pressure rating than the maximum working pressure of the tank.

HAZARD	CAUSE	SAFEGUARDS Prevention of possible hazards.
General Safety	Improper operation or maintenance may create a hazard.	Operators should be given adequate training in the safe use and maintenance of this equipment. Refer to Pressure Systems Safety Regulations 2000 Approved Code of Practice.

03.2 ADDITIONAL SAFETY INFORMATION

Observe all local or municipal safety measures and wear approved protective equipment when servicing this equipment. Clean all spilled chemicals and materials and do all work in a clean and organized environment to prevent personal injury and equipment damage.

04.1 GENERAL SPECIFICATIONS

83C-210-CE & 83Z-210-CE PRESSURE FEED TANK ASSEMBLIES		
	GALVANIZED TANKS (83C)	STAINLESS STEEL TANKS (83Z)
Maximum Working Pressure	5.5 bar [80 PSI]	
Safety Valve Set Pressure	5.5 bar [80 PSI]	
Tank Shell	Steel, Zinc plate 2.4 mm (.094 in)	
Tank Lid	Steel, Zinc plate 4.2 mm (8 Gauge)	300 Stainless Steel, 4.2 mm (8 Gauge)
Lid Gasket	TPV Rubber	
Fluid Tube	Stainless Steel	
Fluid Outlet	Steel, Galvanized Zinc Plate	Stainless Steel
Fluid Outlet Size	3/8" NPS or BSP (M)	
Air Manifold	CRS Zinc Plated	
Air Inlet Size	1/4" NPS or BSP (M)	
Tank Weight	12.8 (kg)	
Tank Height	485 (mm)	
Tank Capacity	9.5 Liters (2.8 US Gallons)	

04.2 DESCRIPTION

NOTICE

These pressure tanks are designed as a pressure container to supply liquid material at a constant preset pressure up to a maximum of 5.5 bar (80 psi). The tanks are built to ASME specifications. 83C models are constructed from electro-zinc plated carbon steel. 83Z models have stainless steel fluid passages and lid. A polyethylene liner is included for easy clean up.

04.3 CERTIFICATIONS

These pressure tanks are CE marked in accordance with Pressure Equipment Directive 2014/68/EU and ATEX Directive 2014/34/EU Protection level Ex h IIB T4 Gb for use in Zones 1 and 2. The agitators are marked in accordance with ATEX Directive 2014/34/EU Protection level Ex h IIB T4 Ga/Gb, and to Machinery Safety Directive 2006/42/EC.

04.4 MODELS

83C-210-CE: Single regulation, electrozinc plated carbon steel construction lid and shell.

83Z-210-CE: Single regulation, electrozinc plated carbon steel shell, stainless steel fluid passages and lids for waterbased materials.

! WARNING

High air pressure loads that are higher than design loads, or changes to the pressure feed tank can cause the tank to rupture or explode.

! WARNING

A safety valve protects the tank from over pressurization. During each use pull the ring on the safety valve to make sure it operates freely and relieves air pressure. If the valve is stuck, does not operate freely, or does not relieve air pressure, it must be replaced. Do not eliminate, make adjustments or substitutions to this valve.

! WARNING

Changes to the air tank will weaken it. Never drill into, weld or change the tank in any way.

! WARNING

High pressure can cause serious injury. Pressure is maintained in a pressure tank after the system has been shut down. Before attempting removal of the cover, pressure must be relieved using the steps below.

! CAUTION

If using an air quick disconnect (Q.D.) at the inlet to the regulator at the pressure tank, do not disconnect the Q.D. while the tank is pressurized, unless the ball valve is closed. Doing so will allow tank pressure to quickly relieve, and can potentially pull paint back through the air regulator and air motor, depending upon the liquid level in the tank. Tank pressure should always be relieved by turning the regulator fully counterclockwise, or pulling the safety valve ring.

05.1 PRESSURE RELIEF STEPS

1. Turn off the main air supply to the tank.
2. Close air inlet valve located on the tank air manifold.
3. Bleed off air in the tank by turning the air relief valve thumb screw counterclockwise. Wait until all the air has escaped through the valve before removing the pressure tank cover.
4. Leave the air relief valve open until you have reinstalled the cover.

06.1 83C-210-CE & 83Z-210-CE TANK ASSEMBLIES

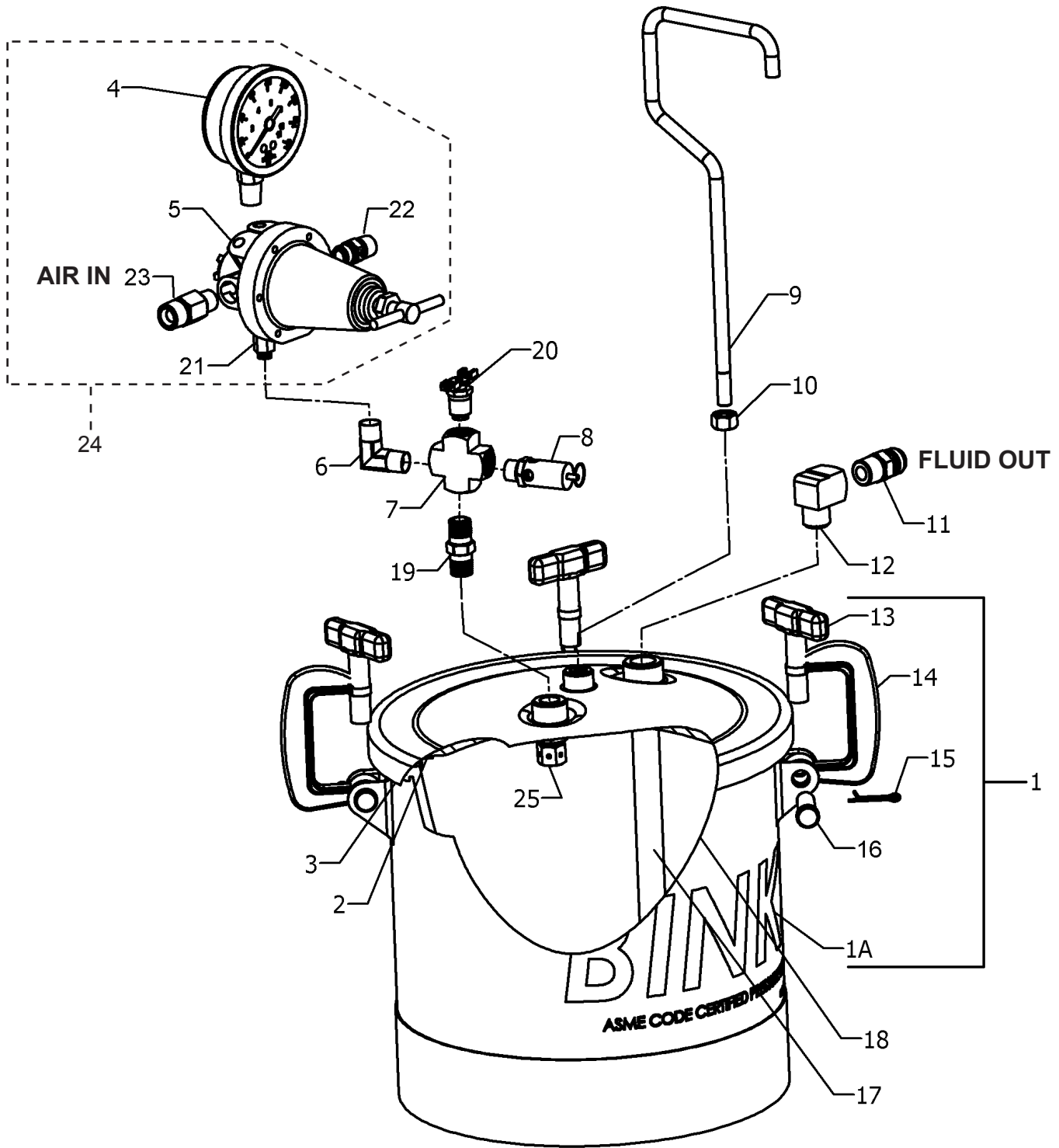

83C-210-CE & 83Z-210-CE TANK ASSEMBLIES PARTS LIST

Item No.	Part No.	Description	Qty.
1	PT-423	Tank Assy. Kit (Includes Ref Nos. 1A, 13, 14, 15 & 16)	1
1A	PT-420	Tank Shell	1
2	PT-33-1	Lid Gasket, Santoprene	1
3	PT-426	83C Lid, Zinc Plated	1
	PT-422	83Z Lid, Stainless Steel	1
4	83-2727	Gauge	1
5	HAR-511	Regulator	1
6	SSP-30-ZN	90° Swivel Adaptor 1/4" NPS (F) x 1/4" NPT (M)	1
7	-	Cross 1/4" NPT (F)	1
8	TIA-4080-CE	Safety Valve - 80 psi	1
9	PT-32	Handle	1
10	-	Hex Nut 3/8" - 16	1
11	AD-11	83C (NPT) Nipple 3/8" NPT (M) x 3/8" NPT (M)	1
	2101007	83C (BSP) Nipple 3/8" NPT (M) x 3/8" BPS (M)	1
	SSP-459	83Z (NPT) Nipple 3/8" NPT (M) x 3/8" NPT (M) S.S	1
	CT-1164	83Z (BSP) Nipple 3/8" NPT (M) x 3/8" BSP (M) S.S	1
12	SSP-1939	Street Elbow 3/8" NPT (F) x 3/8" (M) S.S	1
13	PT-79-CE	Thumb Screw	4
14	-	Yoke Assembly	4
15	-	Cotter Pin, 3/32 x 1"	4
16	-	Hinge Pin	4
17	QMS-9-1	Fluid Tube, S.S	1
18	PT-78-K10 or PT-78-K60	Tank Liner (Kit of 10 or 60)	1
19	SSP-462-ZN	Hex Nipple 1/4" NPT (M)	1
20	SS-2707	Air Relief Valve	1
21	83-4233	D.M Nipple (83C-210)	1
22	H-2008	(NPS) Nipple 1/4" NPT (M) x 1/4" NPS (M)	1
	2101004	(BSP) Nipple 1/4" NPT (M) x 1/4" BSP (M)	1
	83-4233	(NPS) Nipple 3/8" NPT (M) x 1/4" NPS (M)	1
23	2101005	(NPS) Nipple 3/8" NPT (M) x 1/4" NPS (M)	1
24	85-451	Air Control Assembly	1
25	41-646	Diffuser	1

Parts without part numbers listed can be purchased locally.

06.2 HAR-511 REGULATOR ASSEMBLIES

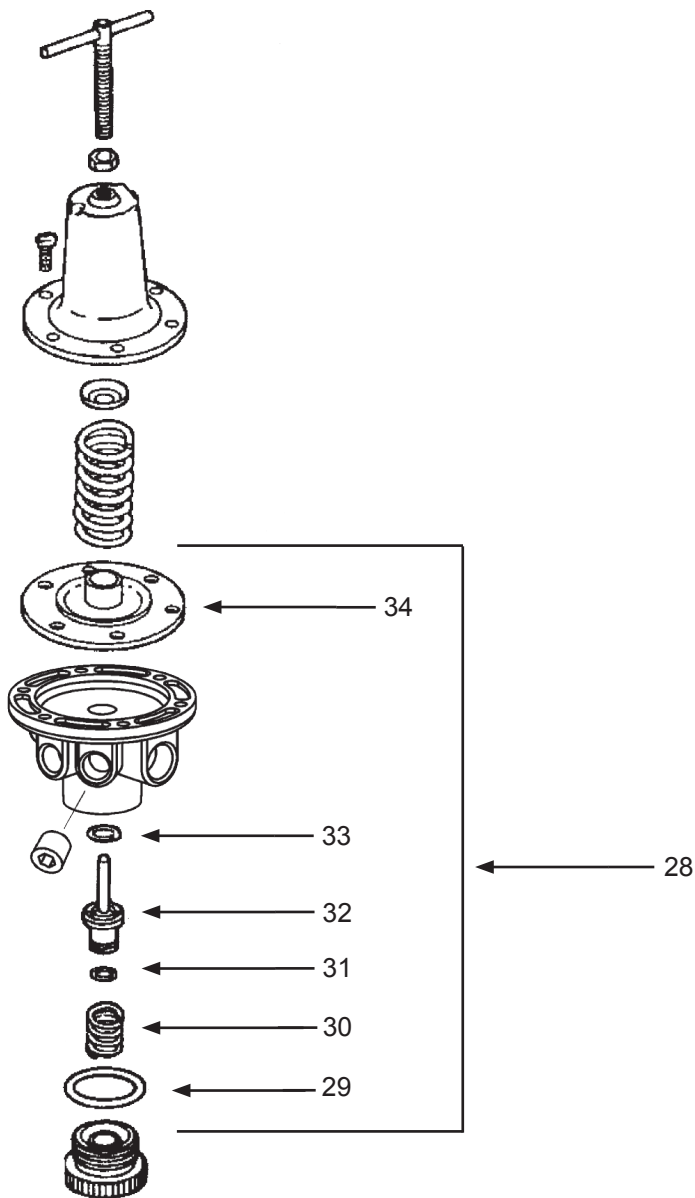

HAR-511 REGULATOR ASSEMBLIES				
Item No.	Part No.	Description	Individual Parts Required	Notes
28	KK-4977	Repair Kit	1	
29	-	"O" Ring	1	+
30	-	Spring	1	+
31	-	"O" Ring	1	+
32	-	Valve	1	+
33	-	"O" Ring	1	+
34	-	Diaphragm Assembly	1	+

+ Included in KK-4977 repair kit

07.1 CLEANING PROCEDURE

1. Turn off the main air supply to the tank.
2. Turn T-handle adjusting screw on tank regulator counterclockwise until no spring tension is felt.
3. Relieve all pressure from the tank by pulling the ring on the safety valve until the pressure bleeds down.
4. Loosen thumb screws, tip clamps back and tip tank lid to one side.
5. Loosen spray gun air cap retaining ring about three turns.
6. To drain down the fluid supply hose to the gun, remove the Aircap and replace with about 2 turns. Turn on the air supply to spray gun and trigger the spray gun into the booth, which will create a back pressure in the fluid line and force the fluid back into the tank.
7. Empty and clean tank and parts which come in contact with material. Use a suitable cleaning material.
8. Pour cleaning material into the tank.

9. Replace lid and tighten thumb screws and clamps.

NOTICE

Tighten down C-clamps to 11 – 13.6 Nm (8-10 ft-lbs) or turn thumb screws approximately 1/2 to 1 turn past hand tight in a cross pattern.

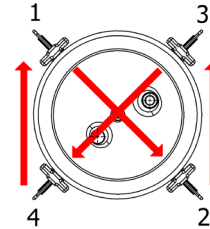

10. Spray until clean solution appears.
11. Repeat steps 5 through 7.

CAUTION

Keep the safety valve clean at all times. Check regularly by pulling the ring to ensure the valve is free to operate.

07.2 SERVICE CHECKS

Condition	Cause	Correction
Air escaping from port on regulator cap	Broken or damaged diaphragm	Replace diaphragm
Pressure creepage registered on gauge	Dirty or worn valve seat in regulator	Clean or replace valve seat
Air leakage from safety valve below maximum working pressure	The valve seat is dry or damaged, or the valve stem assembly is seized	Replace safety valve. Do not attempt to repair
Fluid or air leak at lid gasket	1. Thumb screw not tight 2. Defective lid gasket	1. Tighten 2. Replace

Note: Occasionally check gauge (Ref. no. 9). The needle should return to zero with no pressure on the gauge.

PROSPECTOR™ PRESSURE TANK STRAINERS FOR 2 GALLON TANKS

Prospector™ strainers are an economical way to remove foreign material from paint, stain, lacquer and coatings.

Inner Diameter.....8.75" (222.25mm)
 Outer Diameter..... 10.625" (269.87mm)
 Height/Depth.....2.625" (66.67mm)
 Case Qty..... 20

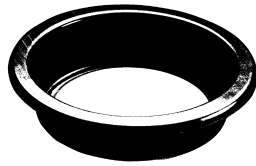

PTS-2Gal-K20-200.....200 micron
 (approx. 65 wire mesh)

PTS-2Gal-K20-400.....400 micron
 (approx. 37 wire mesh)

PTS-2Gal-K20-600.....600 micron
 (approx. 28 wire mesh)

DISPOSABLE TANK LINERS

Single use molded polyethylene tank liners reduce solvent waste and tank cleanup time. The liner is made of tough, durable, leakproof polyethylene and can be used with all compatible materials.

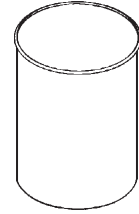

PT-78-K10 Kit of 10 tank liners

PT-78-K60 Kit of 60 tank liners

For additional accessory components including other fluid filters, strainers, regulators and valve options, please visit binks.com.

STATEMENT OF COMPLIANCE

SOUND ENGINEERING PRACTICE IN ACCORDANCE WITH PED 2014/68/EC

Binks® confirms that the products listed below, defined under the Pressure Equipment Directive (PED) 2014/68/EC as 'Pressure Accessories', are below or equal to the limits set out in points (a), (b) and (c) of paragraph 1 and in paragraph 2 respectively and have been designed and manufactured in accordance with Sound Engineering Practice (SEP) Article 4, Paragraph 3. As such, CE marking must not be applied. The equipment is marked under section 3.3 of Essential Safety Requirements of the directive.

PART NO.	DESCRIPTION
VA-527	BALL VALVE, 3/8 NPS OUTLET, S.S.
VA-540	BALL VALVE, 3/8 NPS OUTLET
VA-542	BALL VALVE
HAR-507	AIR REGULATOR
HAR-511	AIR REGULATOR
HAV-500	AIR ADJUSTING VALVE

MANUAL CHANGE SUMMARY

Date	Description	Version
08/15/2025	Revised Safety section	R19
05/08/2025	Rebranded to Binks	R18
05/29/2024	Updated to new template and added tank lid tightening notice	R17

WARRANTY POLICY

This product is covered by Binks' materials and workmanship limited warranty.

The use of parts or accessories from sources other than Binks will void all warranties. Failure to follow reasonable maintenance guidance provided can invalidate the warranty.

For specific warranty information, please contact Binks.

For technical assistance or to locate an authorized distributor, contact one of our international sales and customer support locations listed below.

REGION	BINKS CONTACT
Americas	Tel: 1-800-992-4657
Europe, Africa, Middle East	Tel: +4401202571111
India	marketingroa@binks.com
China	Tel: +862133730108
Korea	Tel: +82313663303
Japan	Tel: +81457856421
Australia	Tel: +61085257555

WARRANTY PAGE

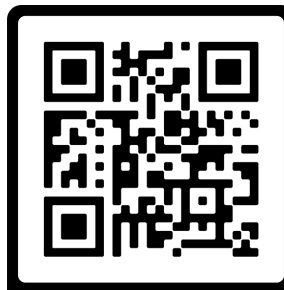



Binks[®]

Binks is a global leader in innovative finishing technologies.
Binks reserves the right to modify equipment specifications without prior notice.
Binks[®], DeVilbiss[®] and Ransburg[®] are registered trademarks of Binks US, LLC.