

AGMDPRO - Automatic Spray Gun

CE  II 2 G X T6

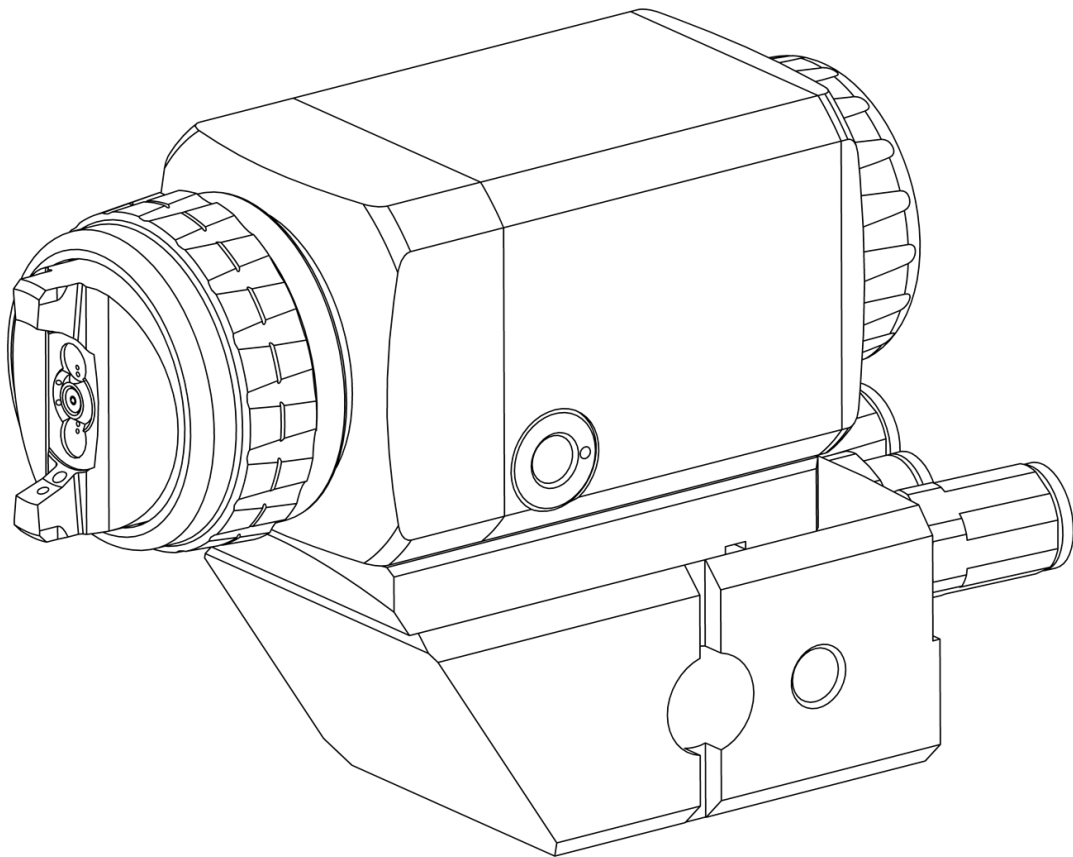

AGMD Pro[®]

IMPORTANT! DO NOT DESTROY

It is the Customer's responsibility to have all operators and service personnel read and understand this manual.

Contact your local Binks representative for additional copies of this manual.

READ ALL INSTRUCTIONS BEFORE OPERATING THIS PRODUCT.

FUNCTIONAL DESCRIPTION

These Sprayguns are suitable for use with both water-based and solvent-based coating materials. They are not designed for use with highly corrosive and/or abrasive materials and if used with such materials it must be expected that the need for cleaning and/or replacement of parts will be increased.

If there is any doubt regarding the suitability of a specific material, contact your DeVilbiss Distributor or Binks direct.

NOTE:

This gun is not to be used with halogenated hydrocarbon solvents or cleaning agents such as 1,1,1-Trichloroethane or methylene chloride. These solvents can react with the aluminium components used in this gun. The reaction can become violent and lead to an equipment explosion.

SPECIFICATIONS

FLUID AND AIR INLET PRESSURES

P1 = Max Air Input Pressure	12 bar [174 psi]
P2 = Max Fluid Input/Recirculation Pressure	15 bar [217 psi]
P3 = Cylinder Air Pressure	3.5 - 6 bar [51 - 87 psi]

ENVIRONMENTAL

Max Ambient Operating Temperature	40°C Nominal [104°F]
-----------------------------------	----------------------

MATERIALS OF CONSTRUCTION

Gun Head and Fluid Passageways	Stainless Steel 303
Gun Body Material	Anodised Aluminium
Air Cap Material	Electroless Nickel Plated Brass
Fluid Tip and Needle Construction	Stainless Steel 303 Acetal Needle Tip
Seals and O-Rings	Viton Extreme Polyethylene

MANIFOLD CONNECTIONS

P1 = Air Inlet Size	1/8" BSP
P2 = Fluid Inlet Size	1/8" BSP
P3 = Cylinder Inlet	1/8" BSP

WEIGHT

Gun only	646g
Gun + Intermediate Plate	715g
Gun + Intermediate Plate + Machine Adaptor	960g

DIMENSIONS - Gun only

L x H x W mm	120 x 46 x 46
--------------	---------------

Product Description / Object of Declaration:	AGMD, AGMD PRO, AGMD PRO CONVENTIONAL
This Product is designed for use with:	Solvent & Waterbased Materials
Suitable for use in hazardous area:	Zone 1/Zone 2
Protection Level:	II 2 G X/Ex h II Gb X
Notified body details and role:	Element Materials Technology Rotterdam B.V. (2812) Lodging of ATEX Technical file
This Declaration of Conformity / Incorporation is issued under the sole responsibility of the manufacturer:	Binks U.K. Limited, Ringwood Road, Bournemouth, BH11 9LH. UK
Representative authorised to compile the technical file	President @. Binks France SAS 5 Place Pierre Semard, 94130 Nogent sur Marne , Paris, France

EU Declaration of Conformity



This Declaration of Conformity / Incorporation is issued under the sole responsibility of the manufacturer:

Machinery Directive 2006/42/EC

ATEX Directive 2014/34/EU

by complying with the following statutory documents and harmonised standards:

EN ISO 12100:2010 Safety of Machinery - General Principles for Design

BS EN 1953:2013 Atomizing and spraying equipment for coating materials - Safety requirements

EN ISO 80079-36:2016 Explosive Atmospheres- Part 36:Non Electrical equipment for explosive atmospheres-Basic methods and requirements.

EN ISO 80079-37:2016 Explosive Atmospheres- Part 37: Non Electrical equipment for explosive atmospheres - protection by methods "c", "b" and "k".

EN 1127-1:2019 Explosive atmospheres - Explosion prevention - Basic concepts

HVLP and High Efficiency products comply with the requirements of PG6 from the EPA guidelines and offer greater than 65% transfer efficiency.

Providing all conditions of safe use / installation stated within the product manuals have been complied with and also installed in accordance with any applicable local codes of practice.

Signed for and on behalf of
Binks U.K. Ltd:

Document Part No.

EN

F. A. Sutter

Executive President: Engineering and
Operations, Shoreview, MN, 55126. USA

09/04/25

Product Description / Object of Declaration:	AGMD, AGMD PRO, AGMD PRO CONVENTIONAL
This Product is designed for use with:	Solvent & Waterbased Materials
Suitable for use in hazardous area:	Zone 1/Zone 2
Protection Level:	II 2 G X/Ex h II Gb X
Approved body details and role:	Element Materials Technology Warwick Ltd. UK. (0891)
	Lodging of UKEX Technical file
This Declaration of Conformity / Incorporation is issued under the sole responsibility of the manufacturer:	Binks U.K. Limited, Ringwood Road, Bournemouth, BH11 9LH. UK

UKCA Declaration of Conformity

**UK
CA**



This Declaration of Conformity / Incorporation is issued under the sole responsibility of the manufacturer:

Supply of Machinery (Safety) Regulations 2008

Equipment and Protective Systems Intended for use in Potentially Explosive Atmospheres Regulations 2016

by complying with the following statutory documents and designated standards:

BS EN ISO 12100:2010 Safety of Machinery - General Principles for Design

BS EN 1953:2013 Atomizing and spraying equipment for coating materials - Safety requirements

BS EN ISO 80079-36:2016 Explosive Atmospheres- Part 36:Non Electrical equipment for explosive atmospheres-Basic methods and requirements.

BS EN ISO 80079-37:2016 Explosive Atmospheres- Part 37: Non Electrical equipment for explosive atmospheres - protection by methods "c", "b" and "k".

BS EN 1127-1:2019 Explosive atmospheres - Explosion prevention - Basic concepts

Providing all conditions of safe use / installation stated within the product manuals have been complied with and also installed in accordance with any applicable local codes of practice.

Signed for and on behalf of Binks
U.K. Ltd:

Document Part No.
EN

F. A. Sutter

Executive President: Engineering and
Operations, Shoreview, MN, 55126. USA

09/04/2025

! WARNING	! CAUTION	NOTE
Hazards or unsafe practices which could result in severe personal injury, death or substantial property damage.	Hazards or unsafe practices which could result in minor personal injury, product or property damage.	Important installation, operation or maintenance information.

! WARNING

Read the following warnings before using this equipment.



SOLVENTS AND COATING MATERIALS. Can be highly flammable or combustible when sprayed. Always refer to the coating supplier's instructions and safety sheets before using this equipment.



INSPECT THE EQUIPMENT DAILY. Inspect the equipment for worn or broken parts on a daily basis. Do not operate the equipment if you are uncertain about its condition.



READ THE MANUAL. Before operating finishing equipment, read and understand all safety, operation and maintenance information provided in the operation manual. Users must comply with all local and national codes of practice and insurance company requirements governing ventilation, fire precautions, operation and house-keeping of working areas.



EQUIPMENT MISUSE HAZARD. Equipment misuse can cause the equipment to rupture, malfunction or start unexpectedly and result in serious injury.



FIRE AND EXPLOSION HAZARD. Never use 1,1,1-Trichloroethane, Methylene Chloride, other Halogenated Hydrocarbon solvents or fluids containing such solvents in equipment with aluminium wetted parts. Such use could result in a serious chemical reaction, with the possibility of explosion. Consult your fluid suppliers to ensure that the fluids being used are compatible with aluminium parts.



GLOVES. Must be worn when spraying or cleaning the equipment.



WEAR SAFETY GLASSES. Failure to wear safety glasses with side shields could result in serious eye injury or blindness.



STATIC CHARGE. Fluid may develop a static charge that must be dissipated through proper grounding of the equipment, objects to be sprayed and all other electrically conductive objects in the dispensing area. Improper grounding or sparks can cause a hazardous condition and result in fire, explosion or electric shock and other serious injury.



WEAR RESPIRATOR. The use of respiratory protective equipment is recommended at all times. The type of equipment must be compatible with the material being sprayed.



TOXIC VAPOURS. When sprayed, certain materials may be poisonous, create irritation, or are otherwise harmful to health. Always read all labels, safety sheets and follow any recommendations for the material before spraying. If in doubt contact your material supplier.



NEVER MODIFY THE EQUIPMENT. Do not modify the equipment unless the manufacturer provides written approval.



LOCK OUT / TAG-OUT. Failure to de-energise, disconnect, lock out and tag-out all power sources before performing equipment maintenance could cause serious injury or death.

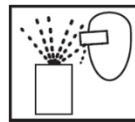

PROJECTILE HAZARD. You may be injured by venting liquids or gases that are released under pressure, or flying debris.



NOISE LEVELS. The A-weighted sound level of pumping and spray equipment may exceed 85 dB(A) depending on equipment settings. Actual noise levels are available on request. It is recommended that ear protection is worn at all times while equipment is in use.



PRESSURE RELIEF PROCEDURE. Always follow the pressure relief procedure in the equipment instruction manual.



KNOW WHERE AND HOW TO SHUT OFF THE EQUIPMENT IN CASE OF AN EMERGENCY.



HIGH PRESSURE CONSIDERATION. High pressure can cause serious injury. Relieve all pressure before servicing. Spray from the gun, hose leaks or ruptured components can inject fluid into your body and cause extremely serious injury.



OPERATOR TRAINING. All personnel must be trained before operating finishing equipment.

IT IS THE RESPONSIBILITY OF THE EMPLOYER TO PROVIDE THIS INFORMATION TO THE OPERATOR OF THE EQUIPMENT.

AGMDPRO GUN PART NUMBER FORMAT & PART SELECTION GUIDE

AIR CAP

TE	High Efficiency
HV	HVLP
R	Round Spray

See table 1

FLUID NOZZLE

Size & construction
See table 2

AGMDPRO U - TE30 - 12 P

GUN HEAD FLUID PASSAGEWAYS

	Single Hole Head Feed
U	Head Recirculation

FLUID NEEDLE

	Stainless Steel
P	Plastic Tipped

TABLE 1 - AGMDPRO AIR CAP RANGE

AIR CAP TYPE	AIR CAP PART NO.	TECHNOLOGY	MARKING ON CAP
HV30C	AGMDPRO-102-HV30C-K	HVLP	HV30C
R40	AGMDPRO-102-R40-K	High Efficiency	R40C
TE30C	AGMDPRO-102-TE30C-K	High Efficiency	TE30C
TE40C	AGMDPRO-102-TE40C-K	High Efficiency	TE40C
TE40SC	AGMDPRO-102-TE40SC-K	High Efficiency	TE40SC
TE50C	AGMDPRO-102-TE50C-K	High Efficiency	TE50C

TABLE 2 - AGMDPRO FLUID NOZZLE AND NEEDLE RANGE - HIGH EFFICIENCY & HVLP

NOZZLE SIZE [mm]	Stainless Steel		Plastic Tipped
	FLUID NOZZLE	FLUID NEEDLE	FLUID NEEDLE
	PART No.	PART No.	PART No.
0.5	PRO-205-05-K	AGMDPRO-301-05-07-K	AGMDPRO-301P-05-07-K
0.7	PRO-205-07-K		
0.85	PRO-205-085-K	AGMDPRO-301-085-10-K	AGMDPRO-301P-08510-K
1.0	PRO-205-10-K		
1.2	PRO-205-12-K	AGMDPRO-301-12-14-K	AGMDPRO-301P-12-14-K
1.4	PRO-205-14-K		
1.6	PRO-205-16-K	AGMDPRO-301-16-18-K	-
1.8	PRO-205-18-K		
2.0	PRO-205-20-K	AGMDPRO-301-20-22-K	-
2.2	PRO-205-22-K		

AGMDPRO AIR CAP PERFORMANCE GUIDE

Air Cap & Type		Part Number	Air Consumption	Recommended Air Inlet Pressure	Typical Fluid Flow*	Typical Fan Pattern Size**
HV30C	HVLP	AGMDPRO-102-HV30C-K	450 L/min [16.0 cfm]	1.75 Bar[26 psi]	160 - 200 ml/min	315mm
R40	High Efficiency	AGMDPRO-102-R40-K	450 L/min [16.0 cfm]	3 Bar[45 psi]	150 - 300 ml/min	∅ 70mm
TE30C	High Efficiency	AGMDPRO-102-TE30C-K	375 L/min [13.3 cfm]	2 Bar[30 psi]	200 - 300 ml/min	300mm
TE40C	High Efficiency	AGMDPRO-102-TE40C-K	355 L/min [12.6 cfm]	2 Bar[30 psi]	250 - 400 ml/min	380mm
TE40SC	High Efficiency	AGMDPRO-102-TE40SC-K	355 L/min [12.6 cfm]	2 Bar[30 psi]	250 - 400 ml/min	380mm
TE50C	High Efficiency	AGMDPRO-102-TE50C-K	425 L/min [15.1 cfm]	2 Bar[30 psi]	250 - 400 ml/min	300mm

* Flow rates may vary according to paint/material and pressure used.

** Fan pattern size @ 200mm distance.

PARTS LIST

REF.	PART No.	DESCRIPTION	QTY.
1	SEE TABLE 1	AIR CAP & RETAINING RING	1
2	AGMDPRO-408-K	RETAINING RING & SEALS	1
3		RETAINING RING	1
4		RETAINING RING SEAL	1
5		AIR CAP	1
6	SEE TABLE 2	FLUID NOZZLE	1
7	AGMDPRO-11-1-K	INDEXING HEAD ASSY	1
8		INDEXING SPRAY HEAD	1
9	SN-98-K2	SPRAY HEAD GASKET	1
10	AGMDPRO-1-1-K	HEAD	1
	AGMDPRO-1-1-U-K	HEAD - RECIRCULATION	
11	AGMDPRO-29X-K5	O RING (KIT OF 5)	5
12	AGMDPRO-9-K2	HEAD GASKET (KIT OF 2)	1
13	AGMDPRO-8-K5	PACKING (KIT OF 5)	1
14		BODY	1
15*		RETAINING SCREW	1
16*		CAM	1
17	AGMDPRO-10-K4	CAP HEAD SCREWS (KIT OF 4)	4
18	AGMDPRO-404-K	PISTON ASSEMBLY	1
19		O RING	1
20		O RING	1
21		PISTON	1
22		PISTON SPRING	1
23	SEE TABLE 2	FLUID NEEDLE	1
24	AGMDPRO-405-K	NEEDLE SPRING ASSEMBLY	1
25		NEEDLE SPRING	1
26		SPRING BUTTON	1
27	AGMDPRO-12-K	END PLATE	1
28	AGMDPRO-13-K	END CAP	1

*	-	LOCKING PIN - Not Shown	1
---	---	-------------------------	---

SERVICE KITS

AGMDPRO-406-K	CAM KIT - (PARTS MARKED WITH * INCLUDED IN KIT)
---------------	---

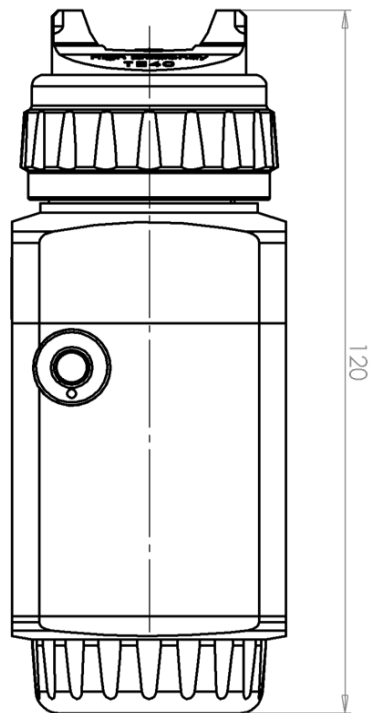
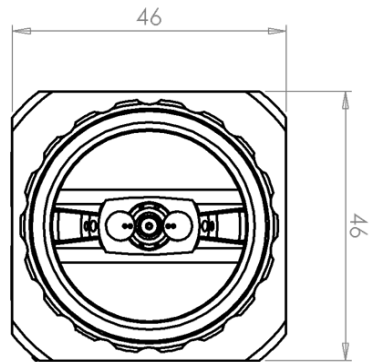
DIMENSIONS (all dimensions in mm)**WARNING**

The spray gun must be earthed to dissipate any electrostatic charges which may be created by fluid or air flows. This can be achieved through the spray gun mounting, or conductive air/fluid hoses. Electrical bond from the spray gun to earth should be checked and a resistance of less than 10^6 Ohms is required.

CONNECTIONS

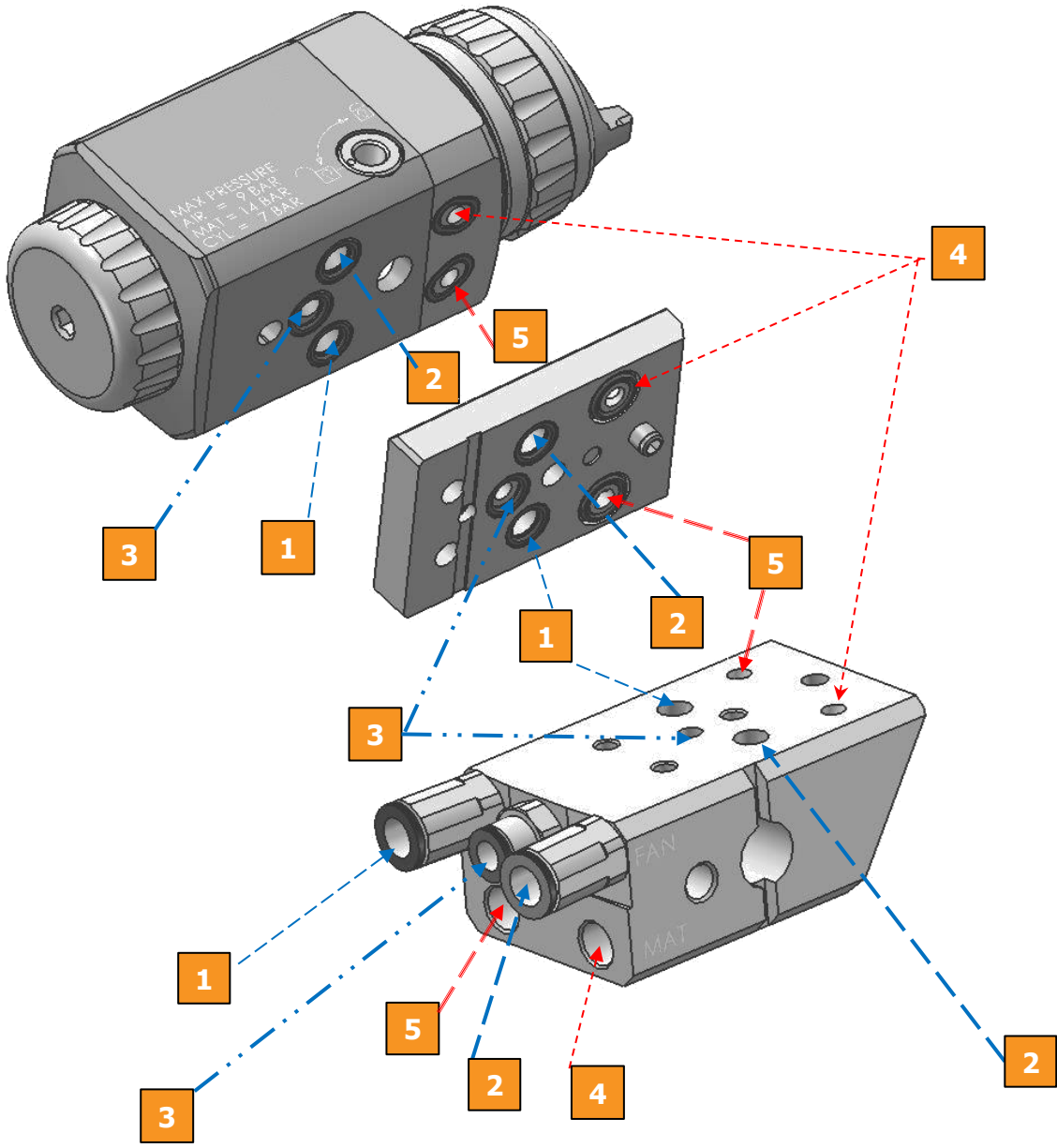

		Supply	Connection Size
1	Atom	Atom Air	1/8" x 8mm
2	Fan	Fan Air	1/8" x 8mm
3	CYL	Cylinder Air	1/8" x 6mm
4	Mat	Fluid	1/8" G
5	Mat R	Fluid Recirculation	1/8" G

NOTE

Protective coatings have been used for storage protection. Flush the equipment fluid passageways with appropriate solvent before use.

OPERATION

GUN REMOVAL AND GUN MOUNT

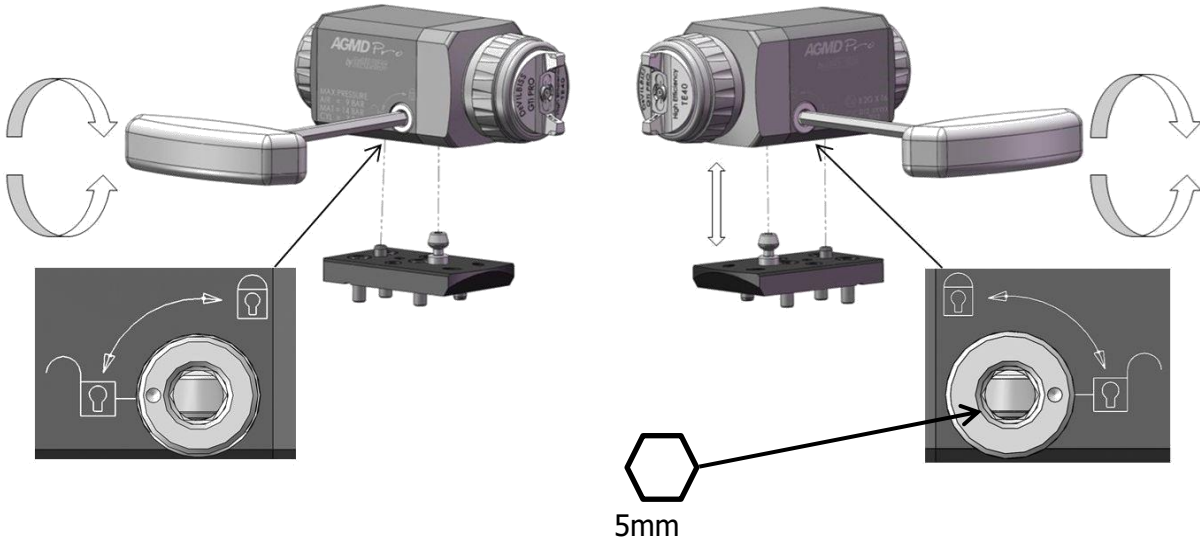

INDEXING AIR CAP 90°



MAINTENANCE

Warning - Check all air and fluid pressure is removed before starting maintenance.



Lubricate with Grease AGMD-010

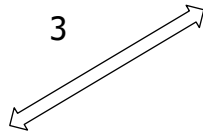

Component direction arrow for dis-assembly and sequence number.
Note: Reverse for assembly

NOZZLE AND NEEDLE REMOVAL

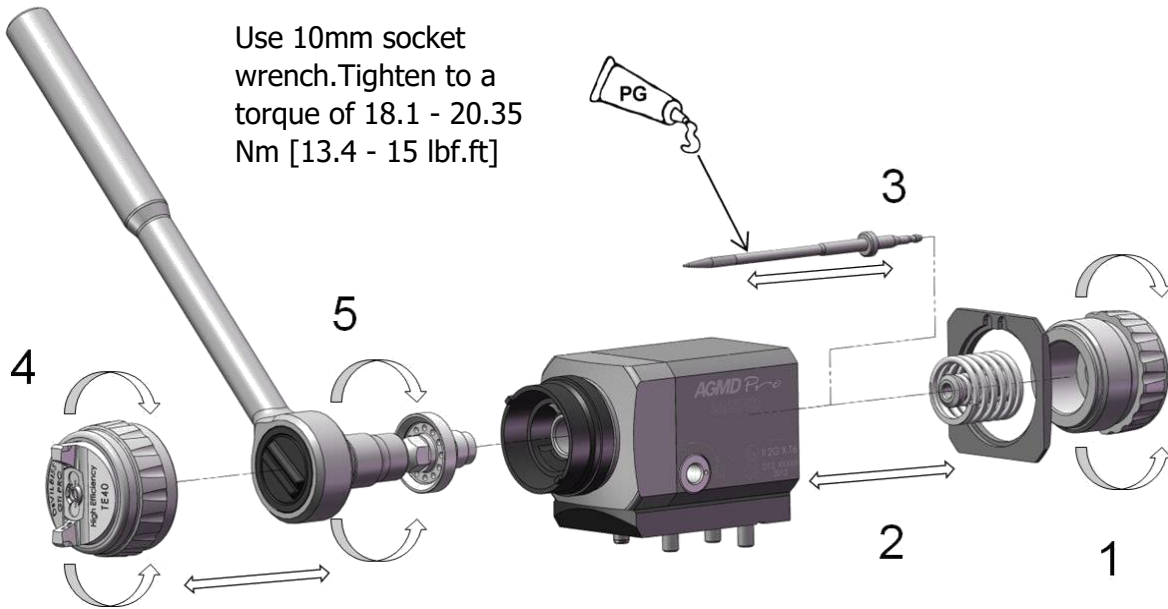

PACKING REMOVAL

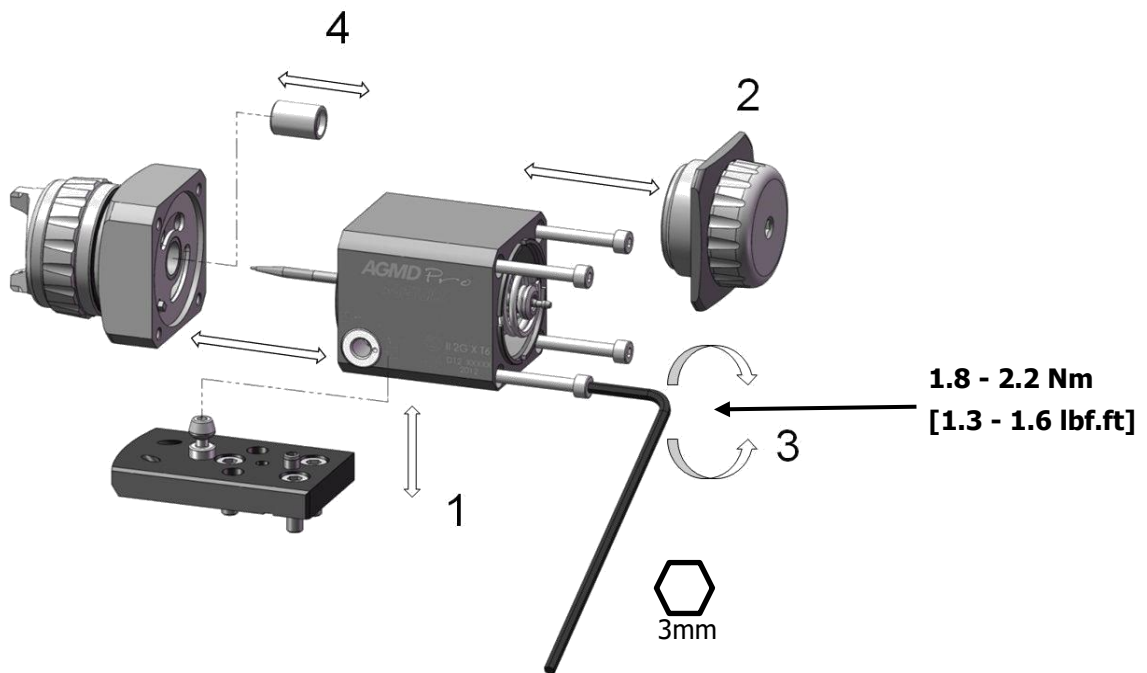

MAINTENANCE

CAM REMOVAL

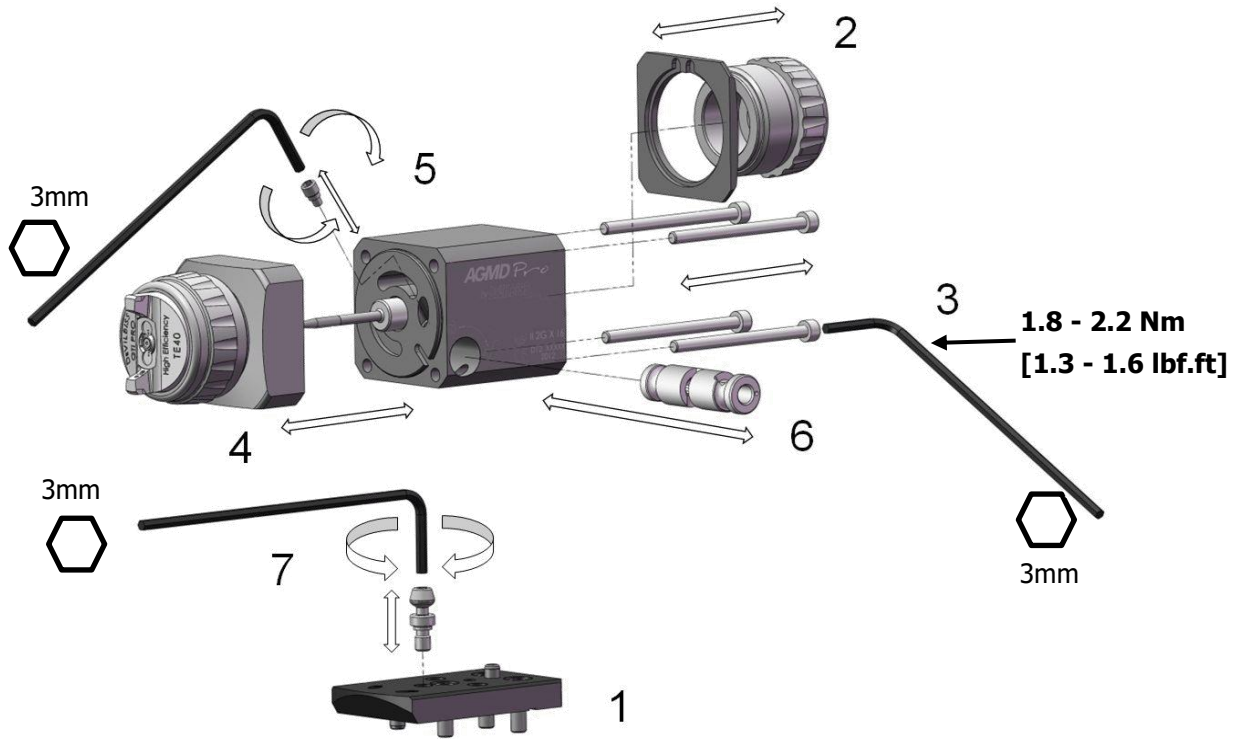

PISTON AND SPRING REMOVAL

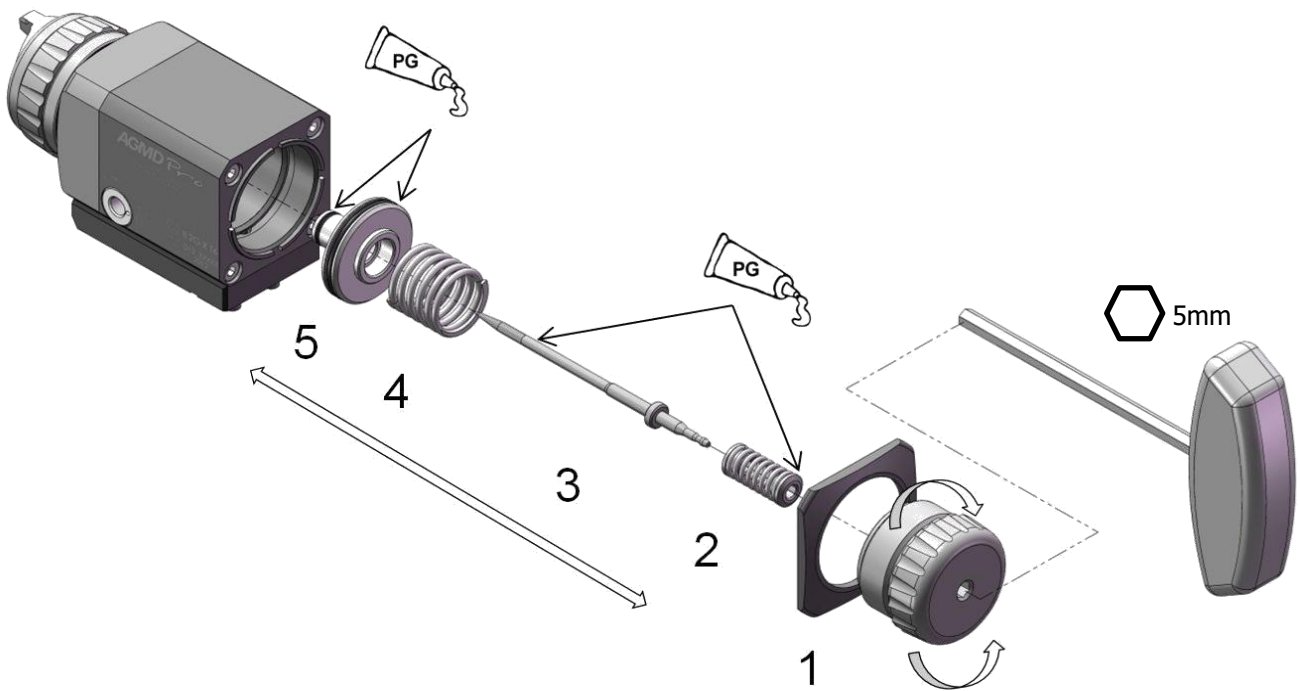

TROUBLESHOOTING SPRAY PERFORMANCE

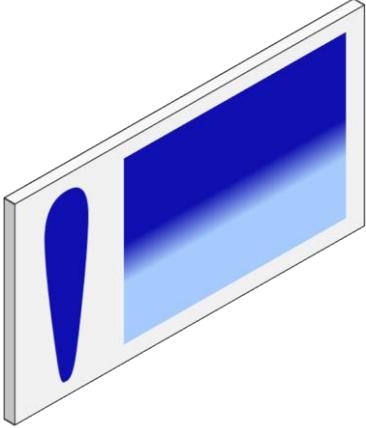
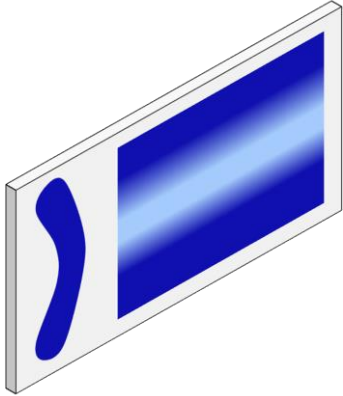
CONDITION	CAUSE	CORRECTION
Heavy top or bottom pattern. 	Material build-up on air cap, plugged horn holes, centre holes or jets.	Soak cap or tip in suitable solvent and thoroughly clean.
	Material build-up on fluid tip exterior or partially plugged fluid tip.	Replace fluid tip or air cap if necessary.
	Fluid tip or cap dirty or damaged.	Replace fluid tip or air cap if necessary.
Heavy right or left side pattern. 	Left or right side horn holes plugged.	Soak cap or tip in suitable solvent and thoroughly clean.
	Dirt or damage on left or right side of fluid tip exterior.	Replace fluid tip or air cap if necessary.
Remedies for the top-heavy, bottom-heavy, right-heavy and left-heavy patterns.		
<p>Determine if the obstruction is on the air cap or the fluid tip. Do this by making a test spray pattern. Then, rotate the cap one-half turn and spray another pattern. If the defect is inverted, obstruction is on the air cap. Clean the air cap as previously instructed. Also check for dried paint just inside the cap centre hole opening, remove by washing with solvent.</p>		
<p>If the defect is not inverted, it is on the fluid tip. Clean tip. If problem persists, renew tip.</p>		

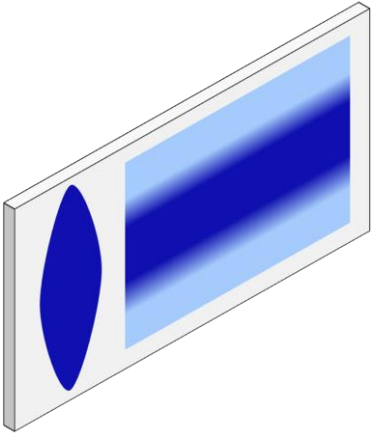
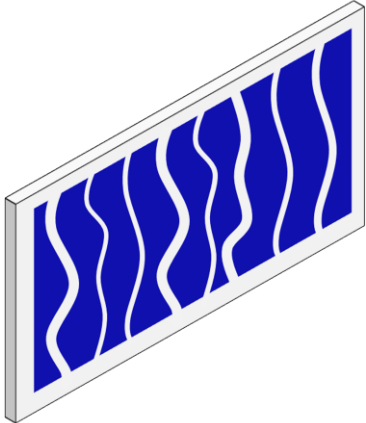
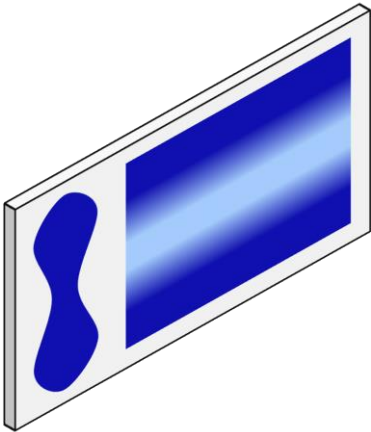
<p>Heavy centre pattern.</p> 	<p>Pattern adjustment valve set too low.</p>	<p>Turn out counter clockwise to achieve correct pattern.</p>
	<p>Too much material.</p>	<p>Reduce fluid flow by turning fluid needle adjusting screw clockwise. Reduce fluid pressure.</p>
	<p>Material too thick.</p>	<p>Thin to correct consistency.</p>
	<p>Atomising air pressure too low.</p>	<p>Increase air pressure.</p>
<p>Intermittent or 'fluttering' spray fan.</p> 	<p>Loose fluid tip.</p>	<p>Tighten.</p>
	<p>Fluid tip not seated correctly in gun head.</p>	<p>Remove fluid tip, clean components, check cone seating on tip and gun for damage or contamination.</p>
	<p>Partially obstructed fluid passage or hose.</p>	<p>Clean or replace.</p>
<p>Split spray pattern</p> 	<p>Not enough material flow.</p>	<p>Increase fluid flow by changing fluid tip size, opening needle control knob or increase fluid pressure on pressure feed container.</p>
	<p>Too high horn pressure.</p>	<p>Reduce air pressure by rotating pattern control valve clockwise.</p>
	<p>Too much air for fluid quantity used.</p>	<p>Reduce input air pressure.</p>

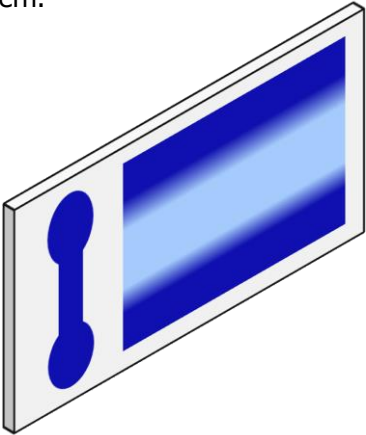
<p>Ball end heavy pattern.</p> 	<p>Too much fluid flow.</p>	<p>Change fluid tip for smaller size or change air cap for different specification air cap.</p>
<p>Excessive bounce-back.</p>	<p>Too much atomisation air pressure.</p>	<p>Reduce air pressure.</p>
	<p>Gun too far from surface.</p>	<p>Check distance (normally 150-200mm).</p>
<p>Runs and sags.</p>	<p>Too much fluid flow.</p>	<p>Adjust gun or reduce fluid pressure.</p>
	<p>Material too thin.</p>	<p>Mix properly or apply light coats/reduce fluid flow.</p>
	<p>Gun tilted at an angle.</p>	<p>Mount gun at right angle to work.</p>
<p>Thin, sandy coarse finish drying before it flows out.</p>	<p>Gun too far from surface.</p>	<p>Check distance.</p>
	<p>Too much air pressure.</p>	<p>Reduce air pressure and check spray pattern.</p>
	<p>Fluid flow too low.</p>	<p>Increase fluid flow by changing fluid tip size, supply pressure or turning needle control knob counter clockwise.</p>

TROUBLESHOOTING MECHANICAL PERFORMANCE

GENERAL FAULTS	CAUSE	CORRECTION
Will not spray.	No air pressure at gun.	Check air supply and air line.
	Fluid needle adjustment knob not open enough.	Open fluid needle adjustment knob.
Gun spits paint when triggering on and off.	Incorrect needle fitted to gun.	Check fluid tip/needle selection chart and fit correct item.
	Excessive needle wear.	Replace with new needle.
	Excessive fluid tip wear.	Replace with new fluid tip.
Gun spits paint when triggering on due to paint build-up inside air cap between spraying operations.	Fluid tip not fitted correctly in gun head.	Tighten.
	Fluid tip/needle leakage.	Check for damage or blockage.
Paint build-up on fluid tip.	Fluid tip not fitted correctly in gun head.	Tighten.
	Fluid tip/needle leakage.	Check for damage or blockage.
Paint build-up on air cap.	Damaged air cap holes.	Replace with new air cap.
	Gradual build-up of bounce-back on gun head.	Thoroughly clean.
Unable to get round spray	Fluid tip or sprayhead incorrectly fitted.	Remove, check components for damage and refit correctly.

When removing air cap from retaining ring, do not remove the ring seat from the retaining ring. Damage to the parts may occur. Simply wipe parts clean and reassemble with new or clean air cap.

FLUID FAULTS	CAUSE	CORRECTION
<p>Slow fluid leak from fluid tip and needle seat.</p>	<p>Fluid tip internal seat scored damaged or worn.</p> <p>Fluid needle external profile damaged or worn.</p> <p>Contamination on needle or tip mating surfaces preventing good seal.</p> <p>Incorrect fluid tip for fluid needle fitted to gun.</p> <p>Sluggish needle.</p> <p>Tight packing nut.</p>	<p>Replace.</p> <p>Replace.</p> <p>Thoroughly clean.</p> <p>Check tip/needle selection chart and fit correct item.</p> <p>Lubricate packing. (GL-1)</p> <p>Adjust.</p>
<p>Fluid leaking between the spray gun and the intermediate plate.</p>	<p>O-Rings damaged or missing.</p> <p>Locking cam not locked or worn.</p>	<p>Replace O-Rings using AGMDPRO-29X-K5.</p> <p>Lock cam or replace using AGMDPRO-406-K.</p>

FLUID FAULTS	CAUSE	CORRECTION
Major fluid leak or fluid jetting from fluid tip and needle seat.	Contamination on needle or tip mating surfaces preventing good seal.	Remove tip and needle and thoroughly clean.
	Incorrect fluid tip for fluid needle fitted to gun.	Check tip/needle selection chart and fit correct item.
Slow fluid leak from needle packing.	Fluid needle packing worn or loose.	Tighten or replace as necessary.

AIR FAULTS	CAUSE	CORRECTION
Small air leak from air cap when gun is not triggered.	Air Valve Stem contaminated and not correctly seating.	Remove Air Valve Stem and thoroughly clean valve shaft and seating surfaces.
	Air Valve Stem seal damaged or missing.	Replace.

ASSEMBLY FAULTS	CAUSE	CORRECTION
Spray gun does not locate onto intermediate plate.	Locking cam is not in the unlock position	Turn locking cam to the unlock position using a 5mm key.
Spray gun is loose when assembled onto intermediate plate.	Locking cam has not been tightened. Locking Cam has worn.	Turn locking cam fully to the lock position using a 5mm key. Replace using cam service kit AGMDPRO-406-K
Spray gun cannot be removed from intermediate plate.	Locking cam is not in the unlock position	Turn locking cam to the unlock position using a 5mm key.

ACCESSORIES

AGMDPRO-402-K INTERMEDIATE PLATE

REF.	PART No.	DESCRIPTION	QTY.
1	-	INTERMEDIATE PLATE	1
2	-	* LOCKING PIN	1
3	AGMDPRO-52-K2	AIR TUBE (KIT OF 2)	2
4	AGMDPRO-29X-K5	O RING (KIT OF 5)	5
5	AGMD-142	SCREW	3

* Included in Cam Kit AGMDPRO-406-K

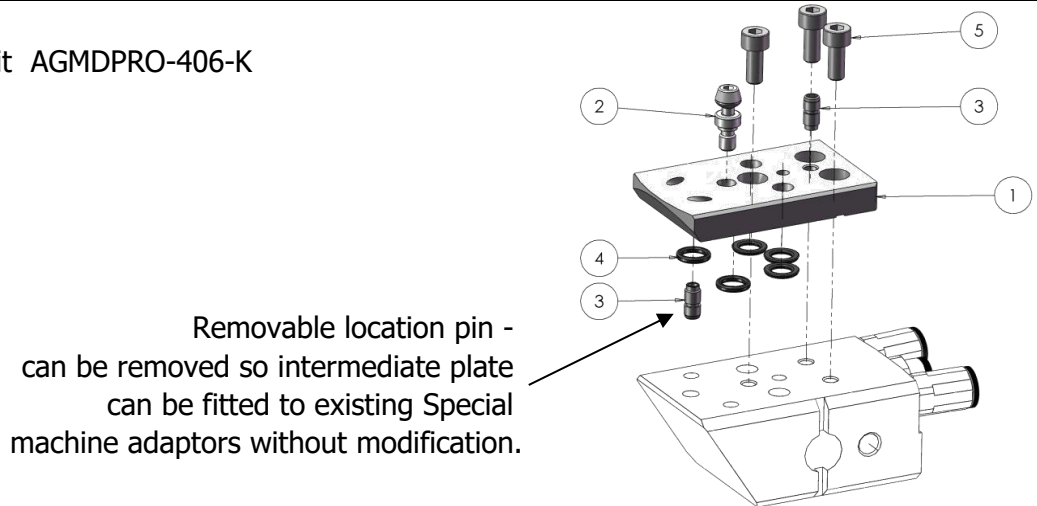

AGMDPRO-403-K MACHINE ADAPTOR

REF.	PART No.	DESCRIPTION	QTY.
1	-	MACHINE ADAPTOR	1
2	SSF-2048	SCREW	1
3	AGMD-126	AIR CONNECTOR 1/8" x 6	2
4	AGMD-127	AIR CONNECTOR 1/8" x 8	5

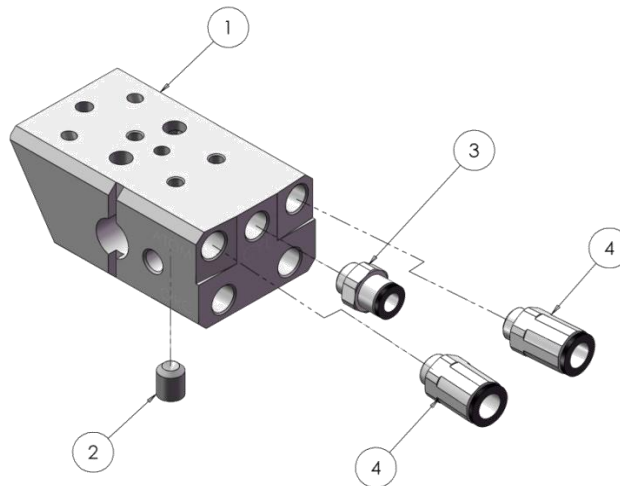

Note: Further machine adaptors and robot mounted adaptors available on request.

WARRANTY POLICY

This product is covered by Binks materials and workmanship limited warranty.

The use of any parts or accessories, from a source other than Binks, will void all warranties. Failure to reasonably follow any maintenance guidance provided, may invalidate any warranty.

For specific warranty information please contact Binks.

For technical assistance or to locate an authorised distributor, contact one of our international sales and customer support locations below.

REGION	BINKS CONTACT
Americas	Tel: 1-888-992-4657
Europe, Africa, Middle East	Tel: +44 (0)1202 571 111
India	marketingroa@binks.com
China	Tel: +8621-3373 0108
Korea	Tel: +82313663303
Japan	Tel: +81 45 785 6421
Australia	Tel: +61 (0) 2 8525 7555

WARRANTY PAGE



Binks

Binks is a global leader in innovative finishing technologies. Binks reserves the right to modify equipment specifications without prior notice.

Binks®, DeVilbiss®, and Ransburg® are registered trademarks of Binks US, LLC.

© 2025 Binks US, LLC. All rights reserved.