



- Model: **76652-01** High Voltage Probe
76652-02 Sprayability/SCI Meter
76652-03 Paint Resistivity Meter
76652-04 Deluxe Kit
A11759-00 High Voltage Probe Adapter

For additional information or copies of your service manual, please visit us online at:

binks.com/en/library

Or use this QR code with your mobile device:

TEST EQUIPMENT FOR ELECTROSTATIC EQUIPMENT



Obey local or municipal regulations for product recycling and disposal.

02. CONTENTS

03 SAFETY	3
03.1 SAFETY PRECAUTIONS	3
03.2 ADDITIONAL SAFETY INFORMATION	10
04 INTRODUCTION	11
04.1 MULTI-FUNCTION ELECTROSTATIC METER	11
04.2 SPRAYABILITY, SCI, AND RESISTANCE MEASUREMENT KIT	13
05 OPERATION	15
05.1 OPERATION	15
05.2 PAINT RESISTANCE MEASUREMENT KIT	19
06 MAINTENANCE	21
06.1 HIGH VOLTAGE MEASUREMENT KIT	21
06.2 GENERAL MAINTENANCE	24
07. MANUAL REVISIONS	25
08. WARRANTY	27

This page intentionally left blank.

03 SAFETY

03.1 SAFETY PRECAUTIONS

Before the operation, maintenance, or servicing of this Binks system; fully read and understand all technical and safety literature for your product. This manual contains information that is important for you to know and understand.

This information relates to USER SAFETY and the PREVENTION OF EQUIPMENT PROBLEMS.

To help you understand this information, we use recognizable ANSI Z535 and ISO warning boxes and symbols throughout this manual. Please obey these safety sections.

⚠ DANGER

DANGER! Indicates a hazardous situation that, if not avoided, will result in death or severe injury.

⚠ WARNING

WARNING! Indicates a hazardous situation that, if not avoided, could result in death or severe injury.

⚠ CAUTION

Caution! Indicates a hazardous situation that, if not avoided, could result in minor or moderate injury, or equipment damage.

NOTICE

Notice: Indicates information considered important but not hazard related.

SAFETY

Safety: Indicates a type of safety instruction, or a separate panel on a safety placard, where specific safety-related instructions or procedures are described.

Careful study and continued use of this manual will provide a better understanding of the equipment functions and procedures.

This understanding will result in improved operation, efficiency, and longer, trouble-free service with faster and easier troubleshooting. If you need the necessary safety literature for your specific system, contact your local Binks representative or Binks directly.

NOTICE

This manual lists standard specifications and service procedures. Differences can occur between this literature and your equipment.

Differences in local or municipal codes, manufacturer or plant requirements, material delivery requirements, and more can make variations unpreventable. To find these differences, compare this manual to your system installation drawings and other applicable Binks equipment manuals.

⚠ WARNING

The user **MUST** read and be familiar with the Safety Section in this manual and the safety literature therein identified.

Only trained personnel can operate this equipment.



All personnel who operate, clean, or maintain this equipment **MUST** fully read and understand this manual! To operate and service the equipment, follow all **WARNINGS** and safety requirements.



The user must be aware of and adhere to **ALL** local building and fire codes and ordinances, as well as NFPA 33 AND EN 16985 SAFETY STANDARDS, LATEST EDITION, or applicable country safety standards, before the installation, operation, or servicing of this equipment.





⚠ WARNING

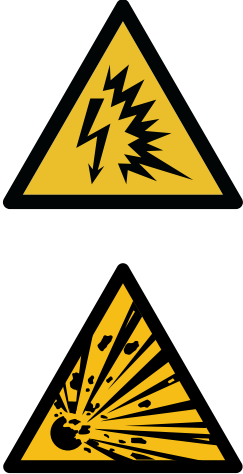

The hazards shown on the pages that follow can occur during the normal use of this Binks equipment, but not all listed hazards will be applicable to your product model or equipment.





Repairs may only be performed by personnel authorized by Binks.

<p>AREAS Indicate possible hazard occurrences.</p>	<p>HAZARDS Indicate possible hazards.</p>	<p>SAFEGUARDS Prevention of possible hazards.</p>
<p>Spray Areas</p>  	<p>Fire Hazards</p> <p>Improper or unsatisfactory operation and maintenance procedures will cause a fire hazard.</p> <p>If the safety interlocks are disabled during operation, protection against accidental arcing is shut off and can cause a fire or explosion.</p> <p>Frequent Power Supply or Controller shutdown identifies a problem in the system. For this occurrence, a correction will be necessary</p>	<p>Fire extinguishing equipment must be present in the spray area. Periodically run a test to make sure the equipment stays usable.</p> <p>Keep spray areas clean to prevent the build-up of combustible residues.</p> <p>Do not smoke in the spray area.</p> <p>The high voltage supplied to the atomizer must be turned off before the equipment is cleaned, flushed or maintained.</p> <p>Spray booth ventilation must be kept at the rates as set by NFPA-33, OSHA, country, local, and municipal codes.</p> <p>If flammable or combustible solvents are used to clean the equipment, ventilate the area.</p> <p>Prevent electrostatic arcing. Maintain spark-safe work distance between the parts that get coated and the applicator. A span of one inch for every 10KV of the output voltage is necessary.</p> <p>Do an equipment test only in areas free of combustible material. The test may necessitate the high voltage to be on, but only as instructed.</p> <p>Non-factory replacement parts or unauthorized equipment modifications can cause a fire or injury.</p> <p>The key switch bypass is used only during setup operation.</p> <p>Do no production work with disabled safety interlocks.</p> <p>Set up and operate the paint procedure and equipment under NFPA-33, NEC, OSHA, local, municipal, country, and European Health and Safety Norms.</p>

<p>AREAS Indicate possible hazard occurrences.</p>	<p>HAZARDS Indicate possible hazards.</p>	<p>SAFEGUARDS Prevention of possible hazards.</p>
<p>Spray Areas</p> 	<p>Explosion Hazard</p> <p>Improper or unsatisfactory operation and maintenance procedures will cause a fire or explosion hazard.</p> <p>If the safety interlocks are disabled during operation, protection against accidental arcing is shut off and can cause a fire or explosion.</p> <p>Frequent Power Supply or Controller shutdown identifies a problem in the system. For this occurrence, a correction will be necessary.</p>	<p>Prevent electrostatic arcing. Maintain spark-safe work distance between the parts that get coated and the applicator. A span of one inch for every 10KV of output voltage is necessary.</p> <p>Unless specifically approved for use in hazardous locations, put all electrical equipment outside of Class I or II, Division 1 or 2 hazardous areas in accordance with NFPA-33, or outside of Zone 2 or Zone 22 in accordance with EN standards.</p> <p>If equipped, set the current overload sensitivity as described in the related section of the equipment manual. If incorrectly set, the current overload sensitivity for protection against accidental arcing is turned off and can cause a fire or explosion.</p> <p>Frequent power supply shutdown indicates a problem in the system, which requires correction.</p> <p>Always turn off the control panel power before the system is flushed, cleaned, or servicing the spray system equipment. Make sure no objects are within the spark-safe work distance before the high voltage is turned on.</p> <p>The control panel must interlock with the ventilation system and conveyor in accordance with NFPA-33, EN 50176.</p> <p>Fire extinguishing equipment must be present in the spray area. Periodically run a test to make sure the equipment stays usable. Do an equipment test only in areas free of combustible material.</p>
<p>General Use and Maintenance</p> 	<p>Improper or unsatisfactory operation and maintenance procedures will cause a fire hazard.</p> <p>Personnel must be correctly trained in the operation and maintenance of this equipment.</p>	<p>Train all personnel in accordance with the requirements of NFPA-33, EN 60079-0.</p> <p>Before equipment operation, personnel must read and understand these instructions and safety precautions.</p> <p>Obey appropriate local, municipal, state, and national codes governing ventilation, fire protection, operation maintenance, and housekeeping.</p> <p>Reference OSHA, NFPA-33, EN Norms, and your insurance company requirements.</p>

<p>AREAS Indicate possible hazard occurrences.</p>	<p>HAZARDS Indicate possible hazards.</p>	<p>SAFEGUARDS Prevention of possible hazards.</p>
<p>Spray Area High Voltage Equipment</p>    	<p>Electrical Discharge</p> <p>This equipment contains a high-voltage device that can cause an electrostatic induction on ungrounded objects. This electrical charge is capable of igniting coating materials.</p> <p>Insufficient ground will cause a spark hazard. A spark can ignite many coating materials and cause a fire or explosion.</p>	<p>Operators in the spray area and the parts to be sprayed must be sufficiently grounded.</p> <p>All conductive objects inside the spray area must be grounded.</p> <p>Hold the parts that get sprayed on conveyors or hangers that are correctly grounded. The resistance between the parts and the earth-ground must not be more than 1 MΩ. Refer to: NFPA-33.</p> <p>Before the equipment is operated, ground all operators. They cannot wear rubber-soled insulated shoes. Wear ground straps on wrists or legs for sufficient ground contact.</p> <p>Operators must not wear or carry ungrounded metal objects.</p> <p>When used, operators must make complete contact with the applicator handle and electrostatic gun. Use conductive gloves or gloves with the palm section cut out.</p> <p>Operators must wear grounded footwear.</p> <p>NOTE: REFER TO NFPA-33 OR SPECIFIC COUNTRY SAFETY CODES FOR GUIDANCE TO CORRECTLY GROUND THE OPERATOR.</p> <p>Except for objects needed for the high-voltage process, all electrically conductive objects in the spray area are to be grounded. Supply a grounded conductive floor in the spray area.</p> <p>Always turn off the applicator voltage before the system is flushed, cleaned, or when servicing the spray system equipment.</p> <p>Unless specifically approved for use in hazardous locations, put all electrical equipment outside of Class I or II, Division 1 or 2 hazardous areas in accordance with NFPA-33, or outside of Zone 2 or Zone 22 in accordance with EN standards.</p> <p>Do not install an applicator into a fluid system if the solvent supply is ungrounded.</p> <p>Do not touch an energized applicator electrode.</p>

<p>AREAS Indicate possible hazard occurrences.</p>	<p>HAZARDS Indicate possible hazards.</p>	<p>SAFEGUARDS Prevention of possible hazards.</p>
<p>Spray Areas</p> 	<p>Toxic Fluid or Fumes</p> <p>Toxic fluids or fumes can cause severe injury or death if splashed in the eyes or on the skin, or if inhaled or swallowed.</p>	<p>Read the Safety Data Sheet (SDS) for instructions to know and understand how to handle the specific hazards of the fluids used, and the effects of long-term exposure.</p> <p>During the spray, clean, or servicing of equipment, or when in the work area, keep the work area fully ventilated.</p> <p>Always wear personal protective equipment (PPE) when in the work area or during equipment operation. Refer to the Personal Protective Equipment warnings in this manual.</p> <p>Store hazardous fluid in approved containers and refer to local, municipal, state, and national codes governing the disposal of hazardous fluids.</p>
<p>Spray Area and Equipment Use</p> 	<p>High-pressure fluid sprayed from the gun, hose fittings, or ruptured/damaged components can pierce the skin.</p> <p>While this injury can appear as cut skin, this is a severe injury that can result in the amputation of the affected area.</p>	<p>Do not point or operate the spray gun at the body part of a person.</p> <p>Do not put your hand or fingers over the gun fluid nozzle or fittings in the hose or Proportioner.</p> <p>Do not try to stop or deflect leaks with your hand, glove, body, or shop rag.</p> <p>Do not “blowback” fluid, as the equipment is not an air spray system.</p> <p>Relieve pressure in the supply hoses, Proportioner, and QuickHeat™ hose before the equipment is inspected, cleaned, or serviced.</p> <p>Use the lowest possible pressure to recirculate, purge, or troubleshoot the equipment.</p> <p>Examine the hoses, couplings, and fittings every day. Service or immediately replace parts that leak, are worn, or are damaged. Replace high-pressure hose sections. They cannot be recoupled or serviced.</p>

<p>AREAS Indicate possible hazard occurrences.</p>	<p>HAZARDS Indicate possible hazards.</p>	<p>SAFEGUARDS Prevention of possible hazards.</p>
<p>Equipment and Fluids</p> 	<p>Skin and Clothing Burns</p> <p>Equipment surfaces and fluids can become very hot during operation.</p>	<p>Do not touch hot fluid or equipment during operation.</p> <p>Do not let clothing touch the equipment during operation or immediately after the equipment is stopped.</p> <p>Let the equipment fully cool before the examination or servicing of the component.</p>
<p>Pressurized Aluminum Parts</p>    	<p>The use of certain solvents and chemicals can cause equipment damage and severe personal injury.</p>	<p>Do not use 1,1,1-trichloroethane, methylene chloride or other halogenated hydrocarbon solvents or fluids that contain such solvents.</p> <p>These solvents can cause a severe chemical reaction and equipment rupture that results in equipment and property damage, serious bodily injury, or death.</p>

<p>AREAS Indicate possible hazard occurrences.</p>	<p>HAZARDS Indicate possible hazards.</p>	<p>SAFEGUARDS Prevention of possible hazards.</p>
<p>Spray Areas</p> 	<p>Do Not Touch</p> <p>The effect of paint flow rates and formulations on the quality of atomization can cause the turbines to rotate at high speeds.</p>	<p>Do not use a rag or gloved hand against the bell edge to stop or slow down a bell during rotation.</p> <p>Do not try to clean the bell edge during rotation.</p>

⚠ CAUTION

Only operate the equipment after you have read this section.

03.2 ADDITIONAL SAFETY INFORMATION

EXAMPLE STATEMENT: *The IntelliFlow has an emergency stop (E-Stop) pushbutton on the main operator panel. During an emergency, all operations for the IntelliFlow will halt when the E-Stop is engaged. The operator must disengage the E-Stop and reset the system to recover from this state.*

Observe all local or municipal safety measures and wear approved protective equipment when servicing this equipment. Clean all spilled chemicals and materials and do all work in a clean and organized environment to prevent personal injury and equipment damage.

⚠ DANGER

To prevent injury or electrocution while the system is under power, do not contact, disconnect, or manipulate electrical connections or devices. The main disconnect on the right side of the controller can be locked out. Follow the proper Lockout-Tagout (LOTO) procedures for internal controller electrical work.

Only qualified electrical personnel can perform the work if diagnosis and troubleshooting are not possible during working conditions.

⚠ WARNING

To prevent possible chemical spillage when personnel are not on site, air and fluid supplies for the equipment must be disabled when the equipment idles for an extended period, such as an end-of-day shutdown.

NOTICE

During the initial commission of the equipment and at periodic times throughout equipment life, visually examine all fluid fittings for leaks.

Periodically, it is necessary to visually examine all pieces of this equipment for signs of noticeable degradation due to chemicals or other conditions in the equipment's environment.

SAFETY

Obey local or municipal regulations that require installed fire suppression for equipment operation.

If the operation of this equipment, sensors, switches, or other ancillary equipment occurs in the presence of flammable gases and vapors, connect this equipment through intrinsic-safe or Zener barriers. Classify them as a 'simple apparatus' or approve them for use in these areas.

04 INTRODUCTION

04.1 MULTI-FUNCTION ELECTROSTATIC METER

The Ransburg Multi-Function Electrostatic Spray Meter uses one meter to serve multi-functions in electrostatic spray finishing. The meter can be used to measure conductivity, paint resistance, short circuit current, resistance, and high voltage. The meter is available in individual kits focused on each function or a deluxe kit, which includes accessories to perform all the functions listed above.

The Ransburg Multi-Function Electrostatic Spray Meter is powered by a single 9V alkaline battery. The solid state circuitry only requires 9V input to power the meter display and condition all the signals from the accessory items.

KITS AND ADAPTERS	
Part #	Description
76652-01	Kit for measuring high voltage. Includes 76634-00 Multi-Function Meter and 76667 High Voltage Probe Assembly.
76652-02	Kit for measuring short circuit current (SCI), resistance and spray-ability. Includes 76634-00 Multi-Function Meter and 76664-00 Test Lead Assembly.
76652-03	Kit for measuring paint resistivity. Includes 76634-00 Multi-Function Meter and 7922-00 Paint Probe Assembly.
76652-04	Deluxe Kit Performs all functions listed above. Includes 76634-00 Multi-Function Meter, 7922-00 Paint Probe Assembly, 76664-00 Test Lead Assembly, and 76667-00 High Voltage Probe Assembly.
A11759-00	High Voltage Probe Adapter Adapter to measure the voltage coming from an individual probe (electrode) assembly on all RMA-MMA Indirect Charge Robot Mounted Rotary Applicator, Aerobell 2.5 Indirect Charge (A10924), and Aerobell II Indirect Charge (77603).

METER SCALE RANGES:*	
kV:	0 to ± 199.9 kVDC
mA:	0 to ± 1999 μ A
k Ω :	1 to 1999 k Ω (.001 to 1.999 M Ω)
M Ω :	00.1M Ω to 199.9 M Ω
GW:	.1G Ω to 19.99 G Ω

* Note: For readings below 2 M Ω , more resolution can be obtained by using the k Ω scale.

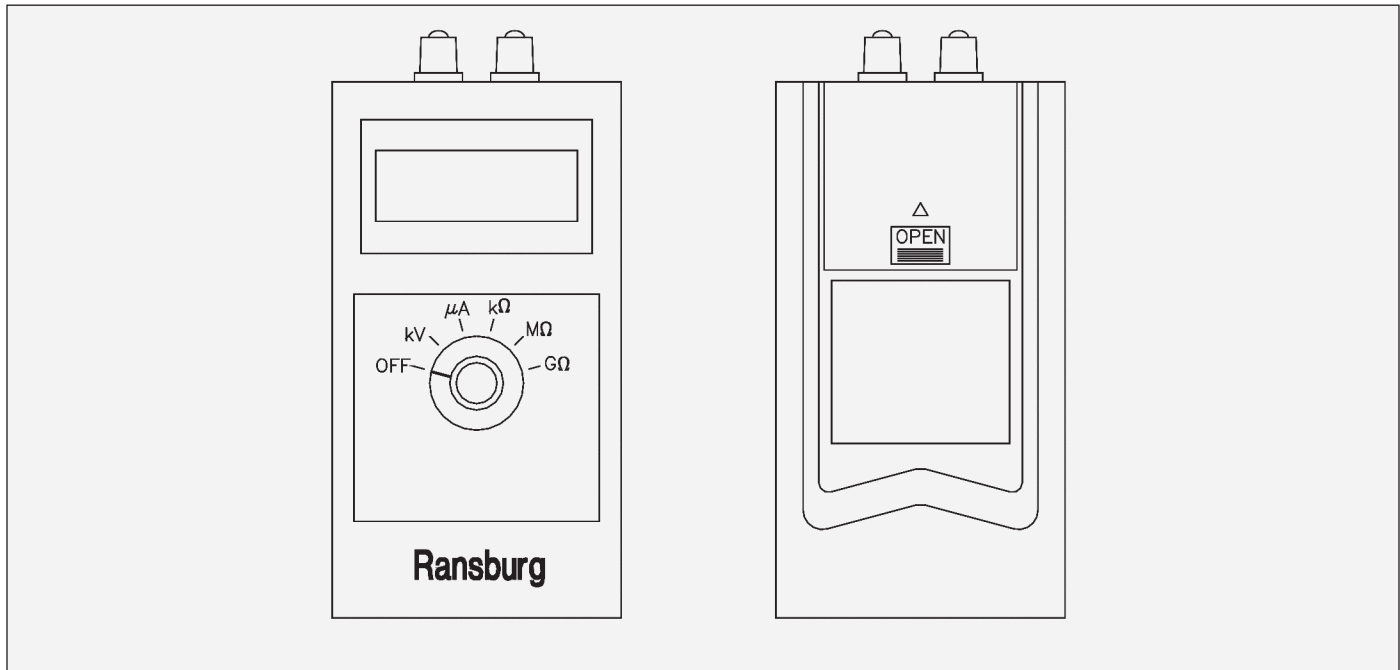

Figure 1A: Multi-Function Meter

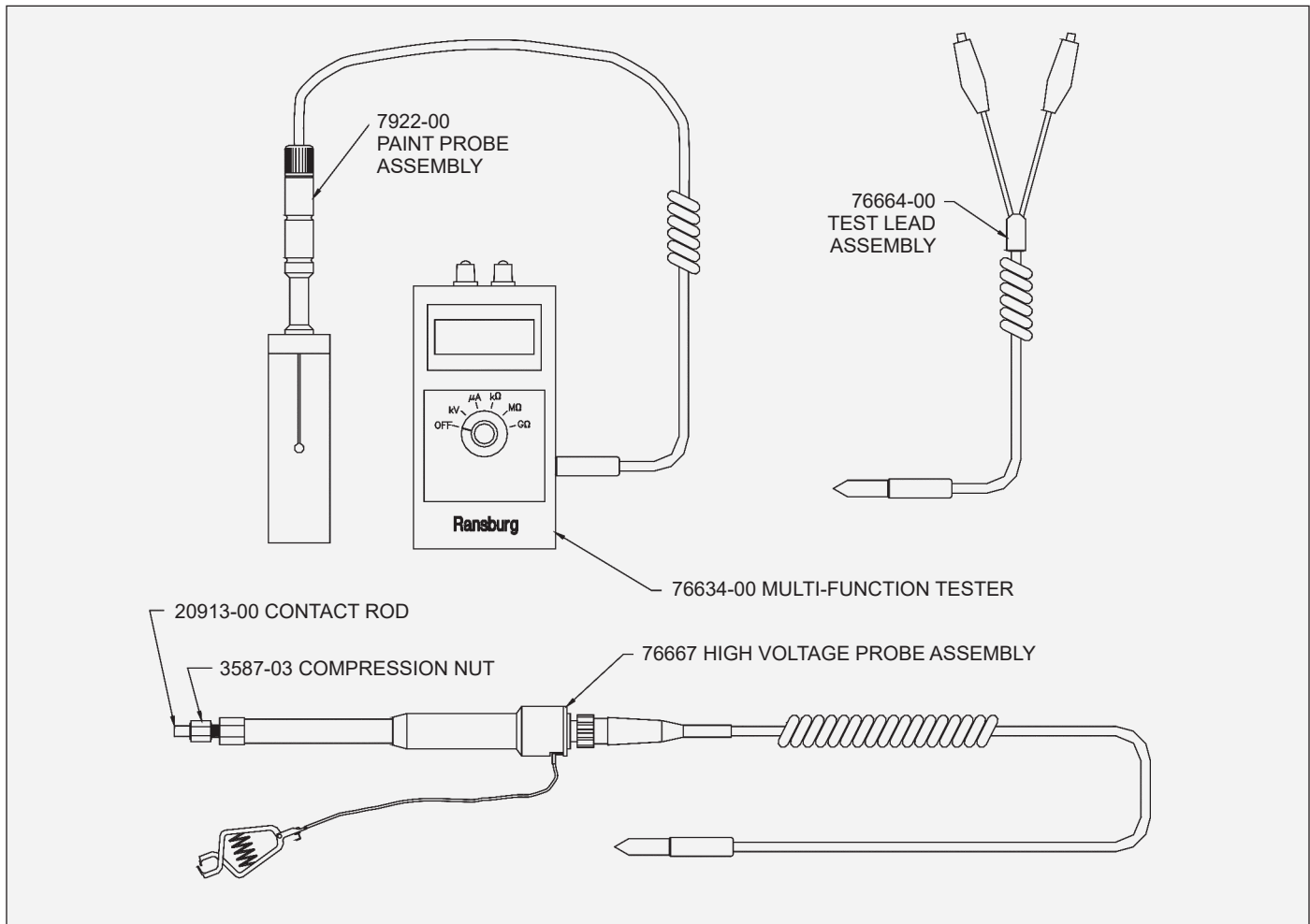

Figure 1B: Multi-Function Meter Kit Parts

04.2 SPRAYABILITY, SCI, AND RESISTANCE MEASUREMENT KIT

Sprayability

The Sprayability Meter measures whether materials normally considered being electrically non-conductive could be electrostatically sprayed or whether they need to be treated with solutions to make the surface conductive. The meter measures the surface resistance and indicates the degree of sprayability in MΩ or GΩ. The target being sprayed must be low enough in resistance to dissipate the electrostatic charge. In some cases the internal resistance of a target is lower than the surface resistance. This might allow a target that does not have a suitable surface resistance reading to be coated electrostatically without additional surface preparation. An example of this is certain types of wood which on the surface are not conductive but due to moisture content (12%-13%) may be sprayable.

Since many non-conductive products must be pre-treated with a conductive solution to make them sprayable, the Ransburg Multi-Function Electrostatic Spray Meter is useful to monitor and maintain consistency in that application, once a suitable reading is determined.

CAUTION

Ensure that meter's scale is properly set for the function in which it is being used. Damage to equipment may result if improperly set.

This page intentionally left blank.

05 OPERATION

05.1 OPERATION

1. Set the meter dial to the $M\Omega$ or $G\Omega$ scale (see Figure 2). Check the meter calibration by touching the metallic end of the two (2) probes on the meter to the stripped bare ends of a single 12" long wire (see Figure 2). (If desired the continuity of the wire may be verified by using a Volt-Ohm meter). If the meter reads zero, the meter is in calibration. If it does not read zero, verify the continuity of the wire and re-perform the check. If the meter still does not read zero, consult the factory for repair of the meter.
2. With the metallic part of the meter probes pressed firmly and perpendicular against the surface of the article to be tested, the meter automatically reads the resistance of the part. Table 1 lists the readings from an 8333-00 meter and compares it to the readings of the Multi-Function Meter.

Meter Readings

0Ω to $1.0G\Omega$ - The article is suitable for spraying using the electrostatic process.

$1.0G\Omega$ to $1.5G\Omega$ - The article is questionable for spraying using the electrostatic process. In such cases, paint a trial sample article to determine if a conductive primer or conductive solution for the part surface is required.

$1.5G\Omega$ to Infinity - The article is **NOT** suitable for spraying. A conductive primer or conductive solution is required to treat the surface of the part.

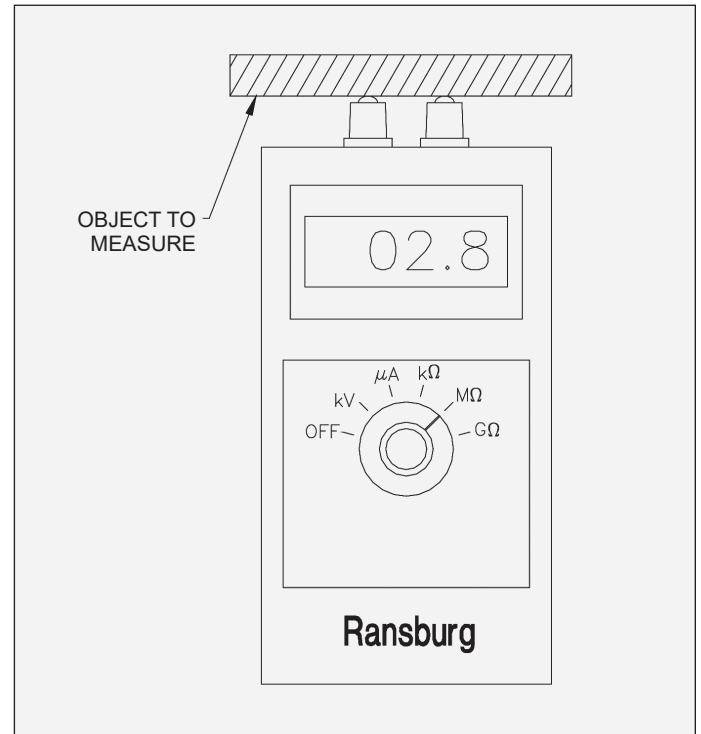

Figure 2: Sprayability Test Meter

TABLE 1 - COMPARISON TO 8333-00 SPRAYABILITY METER WITH NEW MULTI-FUNCTION METER

New 76652-01 Multi-Function Meter Reading	8333-00 Sprayability Meter Reading	Spray Condition
1 MΩ	155	Suitable
2 MΩ	150	Suitable
3 MΩ	147	Suitable
4 MΩ	145	Suitable
14 MΩ	140	Suitable
60 MΩ	135	Suitable
190 MΩ or .1 GΩ	130	Suitable
320 MΩ or .3 GΩ	125	Suitable
410 MΩ or .4 GΩ	120	Suitable
500 MΩ or .5 GΩ	115	Suitable
600 MΩ or .6 GΩ	110	Suitable
760 MΩ or .7 GΩ	105	Suitable
1020 MΩ or 1.0 GΩ	100	Suitable
1.1 GΩ	98	Test Sample Part
1.3 GΩ	95	Test Sample Part
1.5 GΩ	90	Test Sample Part
2.0 GΩ to Infinity	85 or less	Requires Surface Prep

Resistance/TestingTarget/Product Ground

The Ransburg Multi-Function Meter may be used to measure approximate resistance in $k\Omega$, $M\Omega$, or $G\Omega$. Applications for the meter range from measuring the resistance of a 70430-XX resistor to measuring the resistance of a target to ground.

⚠ CAUTION

Ensure that meter's scale is properly set for the function in which it is being used. Damage to equipment may result if improperly set.

NOTICE

When using the Multi-Function Meter test leads to measure resistance or current, ensure that the sprayability probes do not come into contact with any surface or the meter readings may be altered.

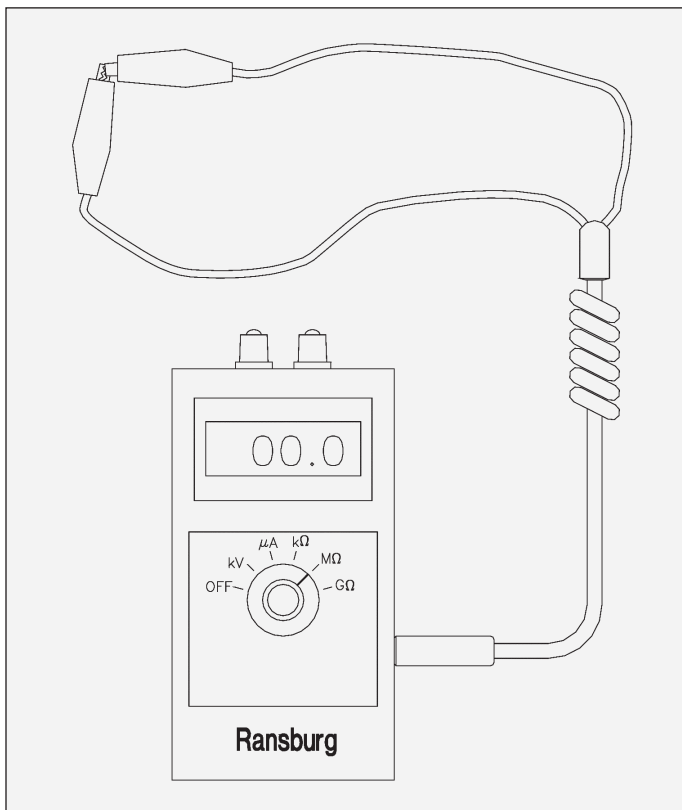

Figure 3: Calibration Check Resistance

Operation

1. Set the meter dial to the $M\Omega$ scale (see Figure 3). Plug the probe with two (2) alligator clamp leads into the side of the meter. Check the meter calibration by touching the metallic ends of the two (2) probes together. If the meter reads zero, the meter is in calibration. If it does not read zero, verify the continuity of the probe assembly and re-perform the check. If the meter still does not read zero, consult the factory for repair of the meter.
2. For ground checks, attach one alligator clip to a clean, non-treated surface of the target to be sprayed. Attach the other alligator clip to a known true earth ground. Set the dial to the $M\Omega$ scale. Read the resistance. If the resistance is greater than $1.0 M\Omega$ the part is not adequately grounded (reference NFPA-77, NFPA-33).

⚠ WARNING

If the reading between true earth ground and the target is greater than $1.0 M\Omega$, then the hooks, racks, supports, etc. must be cleaned and eventually demonstrate a true earth ground resistance of $1.0 M\Omega$ or lower. See NFPA-33 for further information.

3. For resistance checks, set the meter to $M\Omega$ scale (see Figure 4). Attach one alligator clip to the electrode wire of a 70430-XX screwed onto a needle shaft (or similar component). Attach the other lead to the shaft of the needle shaft (or other end of a similar component). The electrode reading should be approximately $14.5 M\Omega$ to $19M\Omega$.

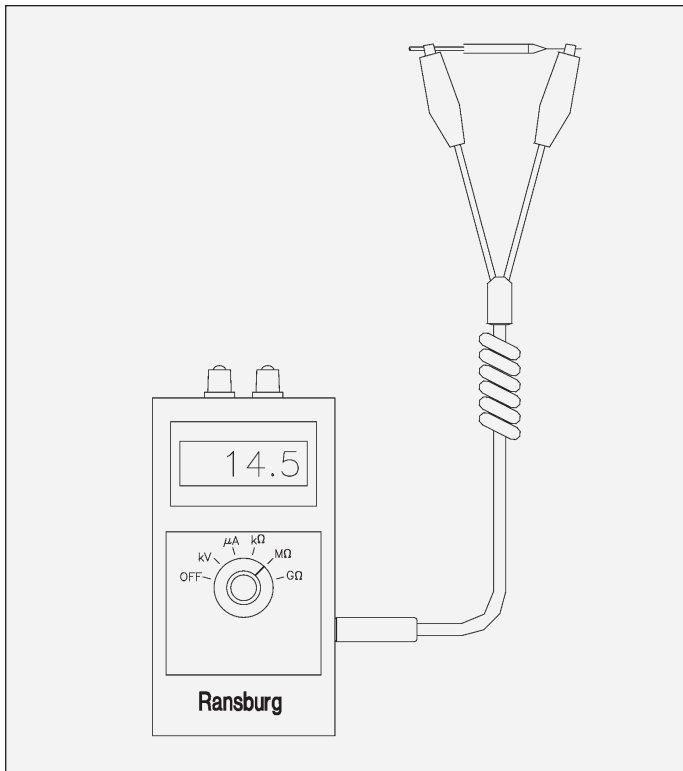

Figure 4: Measuring Electrode Resistance

Short Circuit Current-SCI (Power Supplies)

The Ransburg Multi-Function Meter may be used to measure the short circuit current of an electrostatic product. The short circuit current measurement is important in troubleshooting problems with electrostatic power supplies and applicators. These tests should be performed when a noticeable decrease in transfer efficiency occurs. The measured short circuit current value should be compared to the value listed in the appropriate power supply or applicator manual. This comparison indicates if there are problems with the power source or the applicator.

⚠ CAUTION

Ensure that meter's scale is properly set for the function in which it is being used. Damage to equipment may result if improperly set.

Operation

1. Set the meter dial to the μA scale (see Figure 5). Plug the probe with two (2) alligator clamp leads into the side of the meter. Ensure the meter reads zero. If it does not read zero, consult the factory for repair of the meter.

⚠ WARNING

Prior to starting the SCI tests, ensure the voltage at the power supply is turned off.

2. Place appropriate test resistor in the high voltage cable socket of the power supply. See appropriate power supply or applicator service manual. Be sure it is pushed clear to the bottom or proper contact will not be made. Attach one of the alligator clamps to the lead of the test resistor. Attach the other alligator clamp to a known true earth ground. Turn the power supply on. Then trigger H.V. by the air flow switch or jumper as required by gun model. (See appropriate service manual for further information.) Be sure that the power supply lights indicate that high voltage is being generated. Measure and record the short circuit current from the meter. This value should be compared to the value listed in the appropriate power supply service manual.

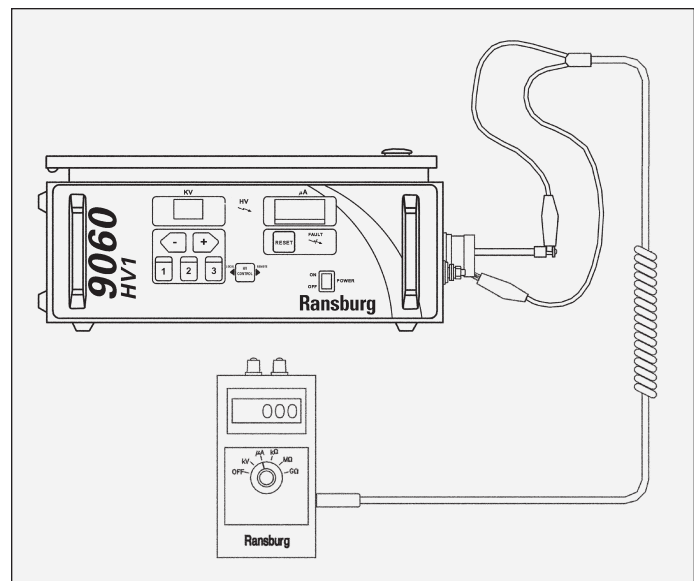

Figure 5: Testing SCI on Power Supplies

Short Circuit Current - SCI (Guns)

The Ransburg Multi-Function Meter may be used to measure the short circuit current of an electrostatic applicator. The short circuit current measurement is important in troubleshooting problems with electrostatic power supplies and applicators. These tests should be performed when a noticeable decrease in transfer efficiency occurs. The measured short circuit current value should be compared to the value listed in the appropriate power supply or applicator manual. This comparison indicates if there are problems with the power source or the applicator.

⚠ CAUTION

Ensure that meter's scale is properly set for the function in which it is being used. Damage to equipment may result if improperly set.

Operation

⚠ WARNING

Prior to starting the SCI tests, ensure the voltage at the power supply is turned off.

1. Set the meter dial to the μA scale (see Figure 5). Plug the probe with two (2) alligator clamp leads into the side of the meter. Check the meter calibration by touching the metallic ends of the two (2) probes together. If the meter reads zero, the meter is in calibration. If it does not read zero, verify the continuity of the probe assembly and re-perform the check. If the meter still does not read zero, consult the factory for repair of the meter.
2. Attach one of the alligator clamps to the electrode (brush on the #2 process bell). Be sure the clamp makes good contact with the electrode (small wires on the #2 brush). Attach the second alligator clamp to ground, preferably the handle or bracket.
3. Apply voltage to the gun from the power supply. The meter should read between the ranges indicated in the power supply and applicator manuals.

05.2 PAINT RESISTANCE

MEASUREMENT KIT

Paint Resistivity

The Ransburg Paint Resistance Measurement Kit using the multi-function meter is designed to provide measurement of the electrical resistance of paint formulations for all electrostatic applications. Once the resistance of a paint is determined and found to spray successfully, measuring resistivity with this meter provides a way to duplicate conditions. This is extremely important when troubleshooting problems with spray or rotational applicators. This meter has two (2) scales, M Ω and k Ω that may be used for measurement of the paint resistance.

⚠ CAUTION

- **Testing Metallic Paint** In certain paint formulations where materials of appreciable content of metal flake or powder (i.e., aluminum, bronze, or metallic colors) are used, this method of testing resistance can be misleading or inconclusive. This paint tester will **NOT** indicate the metallic content of the formula.
- When using the paint tester with metallic paints, the low voltage battery of the test probe may not be enough to influence the metal particles, therefore, their presence may go unrecognized by the meter. When such formulations are placed in electrostatic applicators and high voltage applied, the metal particles may become aligned by the electrical field. This may result in an appreciable increase of current flow to ground by way of the paint delivery system. While the flow of current poses no immediate dangerous condition, it may drain some or all of the voltage from the electrode and may reduce or eliminate electrostatic efficiency.

⚠ CAUTION

Ensure that meter's scale is properly set for the function in which it is being used. Damage to equipment may result if improperly set.

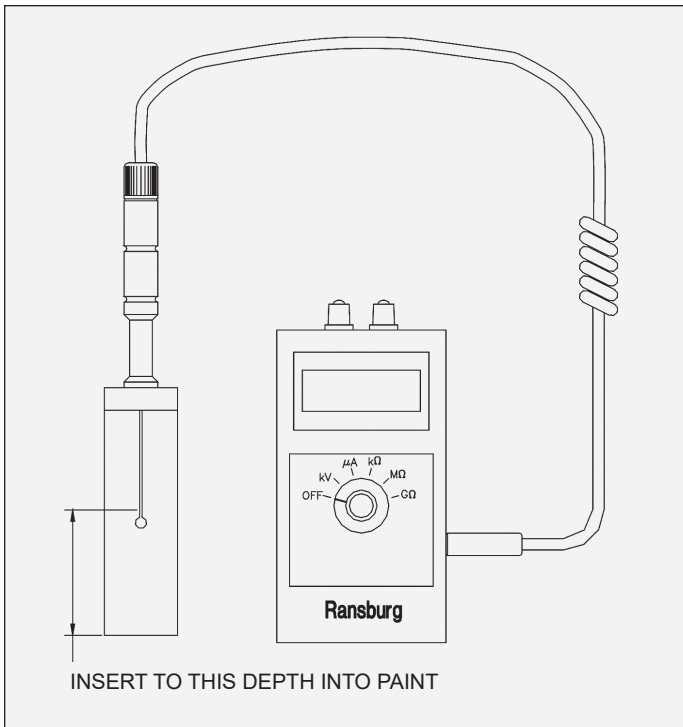

Figure 6: Paint Tester Operation

Operation

1. Set the meter dial to the MΩ scale (see Figure 6). Plug the paint probe into the side of the meter.
2. Immerse the probe vertically into a well-mixed representative sample of the subject paint until the holes at the bottom of the slots in the probe sleeve are submerged (see Figure 6). Take a reading within 5 to 10 seconds of submerging the probe.

⚠ CAUTION
Do not immerse the paint probe past the top of the sleeve.

Meter Readings

Table 4 lists the ranges of paint resistivity that work best for specific Ransburg applicators.

TABLE 4 - PAINT RESISTIVITY RANGES*	
Applicator	Paint Resistivity Range
Rotary Atomizers	0.05 MΩ to 1.0MΩ
#2 Process Handgun	0.1 MΩ to 1.0MΩ
Handguns & Automatic Guns	0.1 MΩ to Infinity

* Use this table as a guideline. Usually a trial for resistance above listed values is recommended. When resistance is below listed values, electrostatic effect will be reduced due to a higher current draw to ground. To spray this material may require other means of increasing distance to ground such as adding coiled fluid tubes.

⚠ CAUTION
NEVER soak the paint probe. There is no solvent seal at the point where the handle screws into the body of the probe. If solvent is allowed to enter at this point or where the cable enters at the top of the handle, the interior wiring will deteriorate and have to be replaced.

MΩ - CM = MΩ reading X 132
(Ref. ASTM D5682)

To obtain MΩ - CM from the resistance in MW from the meter, multiply by 132.

06 MAINTENANCE

Maintenance

The test probe **MUST** be cleaned **IMMEDIATELY** after each use. Use a suitable solvent and clean cloth to thoroughly clean the probe assembly.

1. Remove the probe sleeve and clean it inside and out, removing all paint residues (it may be soaked while probe is cleaned).
2. Thoroughly clean the outside of the probe with the cloth and solvent.
3. Place the cleaned sleeve back on the probe.

06.1 HIGH VOLTAGE MEASUREMENT KIT

High Voltage Measurement

The Ransburg **High Voltage Measurement Kit** using the multi-function meter is designed to provide measurement of high voltage DC potential for all electrostatic applicators to 200kV. Having an accurate measurement of output voltage from an applicator is very important when trouble-shooting problems with an installation. The reading from this device indicates whether the applicator and power supply are operating correctly. This kit comes with the following accessories:

1. A high voltage probe assembly to measure DC voltage at a bell, disk or gun.
2. Five (5) feet of 3/8 inch diameter high voltage cable to measure DC voltage from power supplies of 90kV and higher.
3. Five (5) feet of 5/16 inch diameter high voltage cable to measure DC voltage from power supplies producing less than 90kV.

⚠ CAUTION

Ensure that meter's scale is properly set for the function in which it is being used. Damage to equipment may result if improperly set.

Operation

⚠ CAUTION

Ensure that meter's scale is properly set for the function in which it is being used. Damage to equipment may result if improperly set.

⚠ WARNING

The ground clip **MUST** be connected to a proven true earth ground **BEFORE** any contact is made between the probe assembly and the assembly being tested. All personnel in the hazard (booth) area **MUST** be grounded. See Ransburg bulletin "Personnel Grounding".

These operating instructions **MUST** be read and thoroughly understood by all personnel who use this equipment. Special care should be taken to ensure that all Warnings and Requirements for operating the equipment safely are followed.

The user should be aware of and adhere to all relevant local and company safety and fire codes and ordinances and the Occupational Health Act of 1970 (OSHA) prior to operating this equipment.

1. Set the meter dial to the kV scale (see Figure 7). Plug the high voltage probe into the side of the meter.

⚠ WARNING

To provide proper equipment to operator ground, the conductive handle of the probe **MUST** be held in the bare hand of the operator. To avoid a shock hazard, the meter should **NEVER** be disconnected from the probe during high voltage contact.

2. Attach ground clamp to a proven earth ground.

For Guns

3. If measuring the voltage on an electrostatic gun, line up the hole in the test probe and the electrode. Slide the test probe straight over the electrode wire of the gun. Be sure to push the test probe tight against the nozzle to minimize any voltage that may leak into the air during the test.

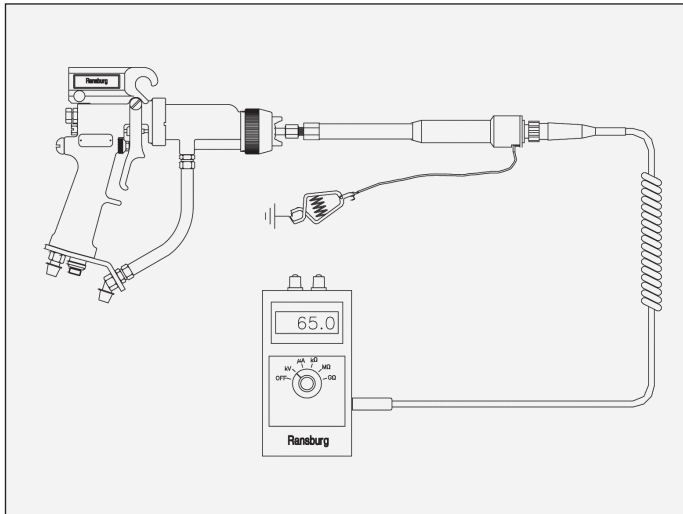

Figure 7: Measuring High Voltage On Electrostatic Air Spray Gun

NOTICE

Make sure all grounded objects are at least 2 feet away.

4. Holding the metal part of the high voltage probe in your hand, trigger the gun so voltage exists at the electrode.
5. Read the voltage displayed on the meter in 30 seconds or less.
6. Turn the voltage to the gun OFF, and pull the test probe straight off the electrode.

For Bells or Disks

7. Turn the high voltage power supply on.
8. Make and maintain sure contact between the test probe and the applicator (see Figure 8).

CAUTION

Ensure that the applicator is **NOT** rotating when contacting it with the probe. Also, to get proper readings on resistive applicators, the probe must be placed in contact with the atomizing edge of the bell or disk as shown in Figure 8. As this edge is sensitive to mechanical damage, use care when contacting it with the probe. Rough handling may cause damage to the applicator.

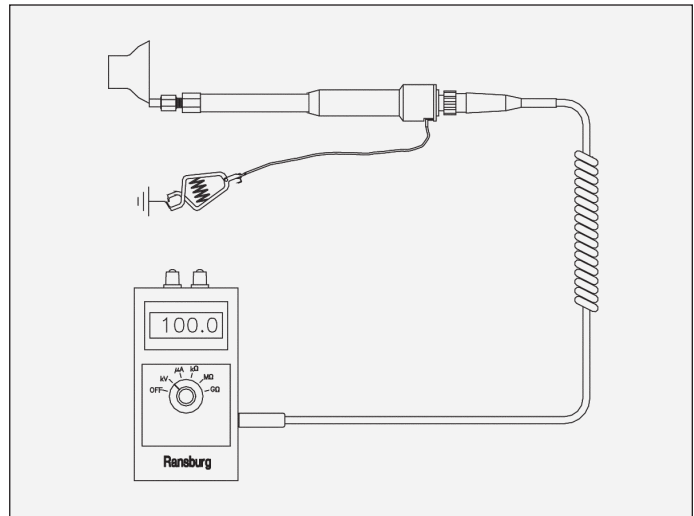

Figure 8: Measuring High Voltage On Bells or Disks

9. Read the applicator high voltage displayed on the meter in 30 seconds or less.
10. Disengage the test probe from the applicator.
11. Resume operation.

For Power Supply High Voltage Measurement

12. Remove the metal test rod by loosening the nut on the end of the wand.
13. Insert the proper diameter high voltage cable into the wand of the high voltage probe.
14. Tighten the nut as necessary.
15. Attach the ground clamp to a known true earth ground.

⚠ WARNING

The ground clip **MUST** be connected to a proven true earth ground **BEFORE** any contact is made between the probe assembly and the assembly being tested.

16. Insert the cable into the high voltage tube of the power supply, inserting it far enough to make contact with the contact spring at the bottom of the tube.
17. Turn the power supply on.
18. Read the voltage displayed on the meter, 30 seconds or less.
19. Turn the power supply off.
20. Disengage the probe cable from the power supply.
21. Restore the applicator connection to the power supply and resume operation.

For Probe (Electrode) Assemblies

22. Turn on the high voltage power supply.
23. Place adapter on end of high voltage probe (see Figure 9).
24. Tighten thumb screw.
25. Place adapter over probe (electrode) assembly (see Figure 10).
26. Remove adapter from probe (electrode) assembly.
27. Test other probe (electrode) assemblies or resume operation.

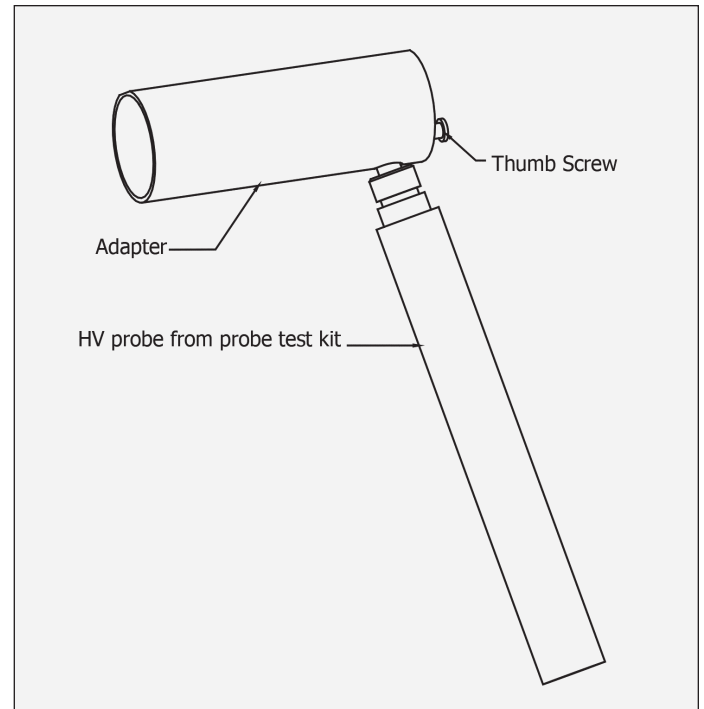

Figure 9: Probe Assembly View

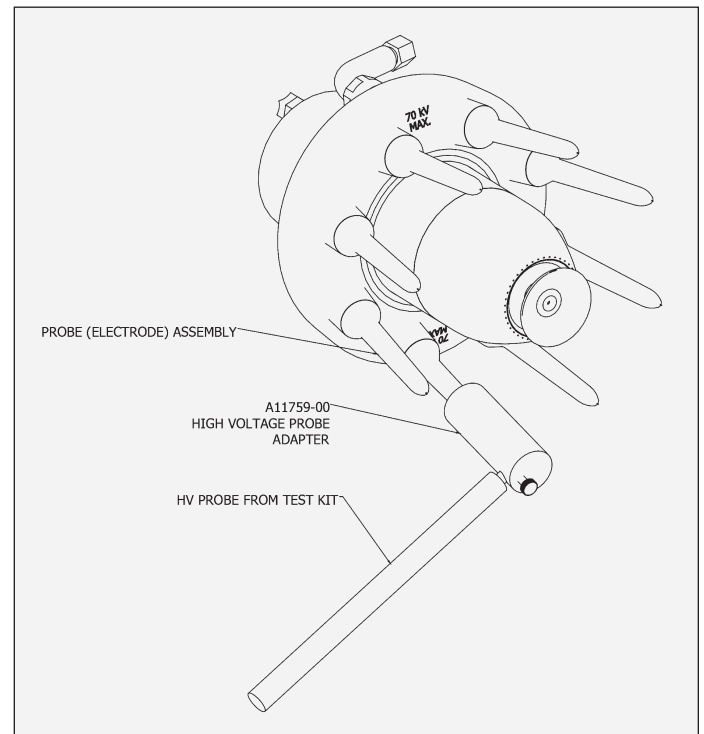

Figure 10: Electrode Test View

Maintenance - Probe

1. Keep the test probe and the HV cables clean to prevent contamination of the probe sockets. Clean only with non-polar solvents.
2. Inspect the ground cable, its clamp and connections for breaks or poor connections.
3. Do not bend or stress the white kV probe assembly, as this may break the potted high voltage resistor.

06.2 GENERAL MAINTENANCE

Maintenance - Battery Replacement

When required, the battery will need to be replaced. It may be purchased locally and is a standard alkaline type 9V battery. To replace the battery, perform the following steps (refer to Figure 11).

1. Remove the sliding back cover of the meter.
2. Remove the existing battery from the two (2) prong 9V connector.
3. Replace with new alkaline 9V battery.
4. Replace back cover.
5. Appropriately discard used battery.

NOTICE

The screen will go blank when the battery needs to be replaced.

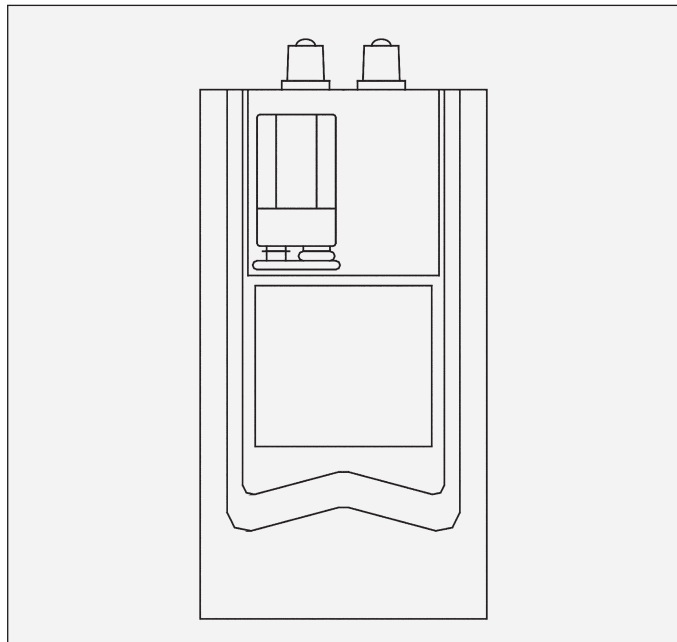

Figure 11: Battery Replacement

Calibration

The 76634-00 Multi-Function Meter is not field repairable. The meter should be returned to the factory for repair or recalibration.

Ransburg recommends that the Multi-Function Meter and its associated equipment (Paint probe, kV Probe, and/or Test Leads) be sent in together for recalibration at least once per year.

NOTICE

The best recalibration results the Multi-Function Meter and accessories (Paint probe, kV Probe, and/or Test Leads) should be sent in together for recalibration.

When shipped from the factory, and after each calibration, the Multi-Function Meter will be sealed with a calibration sticker noting the next date when calibration expires. Removal of this seal will void calibration of the unit. A certificate of calibration will also be shipped with each calibrated unit.

MANUAL CHANGE SUMMARY

Date	Description	Version
08/2025	Rebranding and update to new manual design.	R10

This page intentionally left blank.

WARRANTY POLICY

This product is covered by Binks' materials and workmanship limited warranty.

The use of parts or accessories from sources other than Binks will void all warranties. Failure to follow reasonable maintenance guidance provided can invalidate the warranty.

For specific warranty information, please contact Binks.

For technical assistance or to locate an authorized distributor, contact one of our international sales and customer support locations listed below.

REGION	BINKS CONTACT
Americas	Tel: 1-800-992-4657
Europe, Africa, Middle East	Tel: +4401202571111
India	marketingroa@binks.com
China	Tel: +862133730108
Korea	Tel: +82313663303
Japan	Tel: +81457856421
Australia	Tel: +61085257555

WARRANTY PAGE

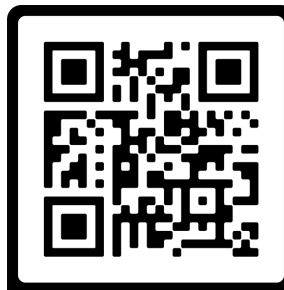

Binks

Binks is a global leader in innovative finishing technologies.
Binks reserves the right to modify equipment specifications without prior notice.
Binks®, DeVilbiss® and Ransburg® are registered trademarks of Binks US, LLC.