

### MODEL 149-873 & 149-874 HIGH-SPEED QUICK MIXER

#### ⚠ WARNING

Disconnect air supply from the agitator before attempting any service maintenance.

#### ⚠ WARNING

**ENTANGLEMENT HAZARD!**  
Keep clear of paddles during operation. Paddles are rotating and have sharp edges.

#### ⚠ WARNING

This product does not meet ATEX requirements for use with hazardous materials.

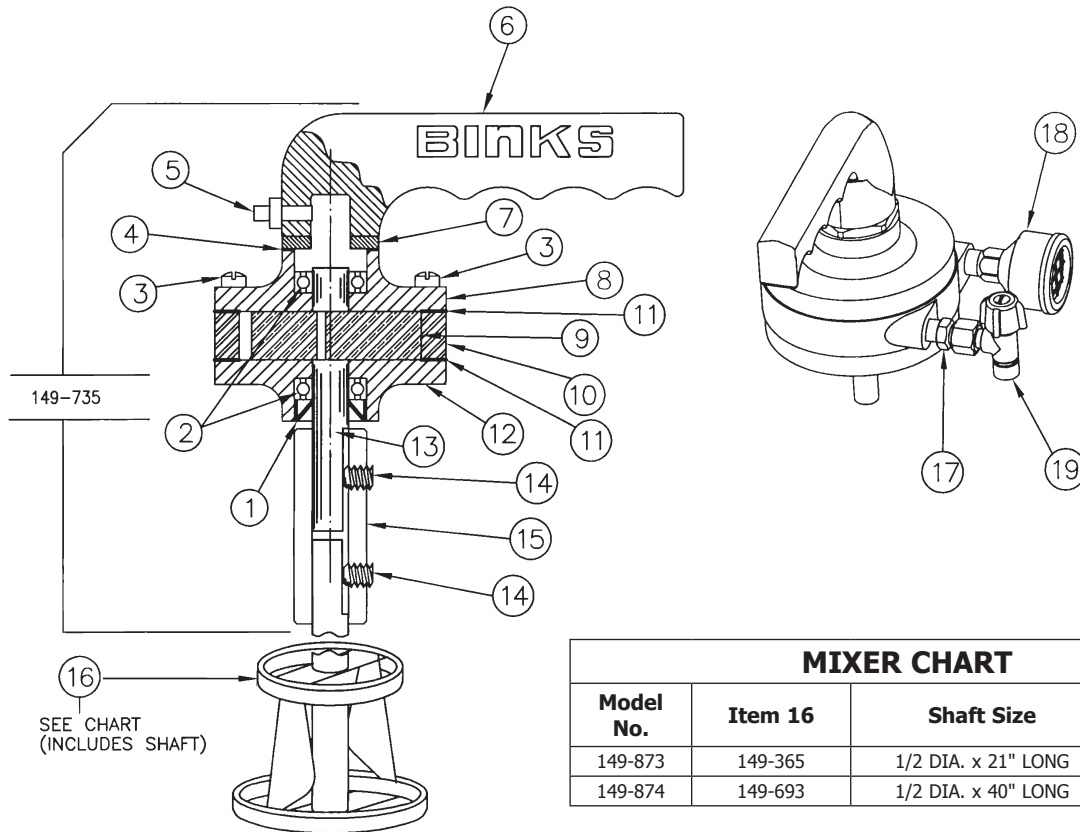

#### MIXER CHART

Model No.	Item 16	Shaft Size	Mixer Disc Dia.
149-873	149-365	1/2 DIA. x 21" LONG	5"
149-874	149-693	1/2 DIA. x 40" LONG	5"

#### PARTS LIST

Ref. No.	Replacement Part No.	Description	Ind. Parts Req'd.
1	37-90 +●	OIL SEAL	1
2	37-91 +●	BEARING	2
3	— +	FILLISTER HD. SCREW (2 SHOWN)	12
4	QS-181 +●	GASKET	1
5	37-414	OILER	1
6	149-734	HANDLE	1
7	149-736	LOCKNUT	1
8	— +	PLATE, DEAD END	1
9	37-92 +●	VANE	4
10	— +	BODY	1

Ref. No.	Replacement Part No.	Description	Ind. Parts Req'd.
11	37-337-5 +●◆	GASKET, END PLATE	2
12	— +	PLATE, DRIVE END	1
13	— +	ROTOR	1
14	20-3344	SET SCREW ALLEN HD. (CUP PT 10-32 x 1/4 LONG)	2
15	149-761	COUPLING (1/2" x 1/2")	1
16	—	QUICK MIXER (SEE CHART)	1
17	57-13-1	D.M. NIPPLE	1
18	83-1527	MUFFLER	1
19	73-159	METERING VALVE ASSEMBLY	1

+ Indicates parts that are included in 83-1922 air motor. The 83-1922 air motor is available as a replacement item.

● Available as part of Repair Kit 6-183.

◆ Also available in quantity pack of five (37-337-5).

**NOTE:** The hand mixer air motor assembly (149-735) is available as a replacement item. 149-735 includes items 1 through 15 plus items 17, 18 and 19.

In this part sheet, the words **WARNING**, **CAUTION** and **NOTE** are used to emphasize important safety information as follows:

## **WARNING**

Hazards or unsafe practices which could result in severe personal injury, death or substantial property damage.

## **CAUTION**

Hazards or unsafe practices which could result in minor personal injury, product or property damage.

## **NOTE**

Important installation, operation or maintenance information.

## **WARNING**

### Read the following warnings before using this equipment.



#### READ THE MANUAL

Before operating finishing equipment, read and understand all safety, operation and maintenance information provided in the operation manual.



#### OPERATOR TRAINING

All personnel must be trained before operating finishing equipment.



#### EQUIPMENT MISUSE HAZARD

Equipment misuse can cause the equipment to rupture, malfunction, or start unexpectedly and result in serious injury.



#### LOCK OUT / TAG-OUT

Failure to de-energize, disconnect, lock out and tag-out all power sources before performing equipment maintenance could cause serious injury or death.



#### AUTOMATIC EQUIPMENT

Automatic equipment may start suddenly without warning.



#### PRESSURE RELIEF PROCEDURE

Always follow the pressure relief procedure in the equipment instruction manual.



#### KEEP EQUIPMENT GUARDS IN PLACE

Do not operate the equipment if the safety devices have been removed.



#### KNOW WHERE AND HOW TO SHUT OFF THE EQUIPMENT IN CASE OF AN EMERGENCY



#### WEAR SAFETY GLASSES

Failure to wear safety glasses with side shields could result in serious eye injury or blindness.



#### INSPECT THE EQUIPMENT DAILY

Inspect the equipment for worn or broken parts on a daily basis. Do not operate the equipment if you are uncertain about its condition.



#### NEVER MODIFY THE EQUIPMENT

Do not modify the equipment unless the manufacturer provides written approval.



#### NOISE HAZARD

You may be injured by loud noise. Hearing protection may be required when using this equipment.

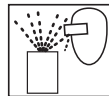

#### PROJECTILE HAZARD

You may be injured by venting liquids or gases that are released under pressure, or flying debris.



#### PINCH POINT HAZARD

Moving parts can crush and cut. Pinch points are basically any areas where there are moving parts.



#### STATIC CHARGE

Fluid may develop a static charge that must be dissipated through proper grounding of the equipment, objects to be sprayed and all other electrically conductive objects in the dispensing area. Improper grounding or sparks can cause a hazardous condition and result in fire, explosion or electric shock and other serious injury.



#### WEAR RESPIRATOR

Toxic fumes can cause serious injury or death if inhaled. Wear a respirator as recommended by the fluid and solvent manufacturer's Safety Data Sheet.



#### TOXIC FLUID & FUMES

Hazardous fluid or toxic fumes can cause serious injury or death if splashed in the eyes or on the skin, inhaled, injected or swallowed. LEARN and KNOW the specific hazards of the fluids you are using.



#### FIRE AND EXPLOSION HAZARD

Improper equipment grounding, poor ventilation, open flame or sparks can cause a hazardous condition and result in fire or explosion and serious injury.



#### MEDICAL ALERT

Any injury caused by high pressure liquid can be serious. If you are injured or even suspect an injury:

- Go to an emergency room immediately.
- Tell the doctor you suspect an injection injury.
- Show the doctor this medical information or the medical alert card provided with your airless spray equipment.
- Tell the doctor what kind of fluid you were spraying or dispensing.



#### GET IMMEDIATE MEDICAL ATTENTION

To prevent contact with the fluid, please note the following:

- Never point the gun/valve at anyone or any part of the body.
- Never put hand or fingers over the spray tip.
- Never attempt to stop or deflect fluid leaks with your hand, body, glove or rag.
- Always have the tip guard on the spray gun before spraying.
- Always ensure that the gun trigger safety operates before spraying.

**IT IS THE RESPONSIBILITY OF THE EMPLOYER TO PROVIDE THIS INFORMATION TO THE OPERATOR OF THE EQUIPMENT. FOR FURTHER SAFETY INFORMATION REGARDING THIS EQUIPMENT, SEE THE GENERAL EQUIPMENT SAFETY BOOKLET (77-5300).**

## BINKS MODEL 149-873 & 149-874 HIGH-SPEED QUICK MIXER

The Binks High Speed Quick-Mixers are hand-held, compact, and versatile units for use in the shop or on the job.

A unique feature of the Quick Mixer is the vertical and horizontal blade design which moves the material toward the center of the mixer at all times assuring thorough blending. The mixer is also designed to scrape the bottom and sides of the container without injuring the mixer or puncturing container walls.

A table of approximate mixing speeds is shown below for your convenience. The use of an electric drill is not recommended for mixing paint or other highly flammable materials.

MIXER CHART		
Model Numbers	Diameter of Mixer Unit	Outer Rim Travel in FPM @ 600 RPM
149-365 MIXER	5"	785.4
149-693 MIXER	5"	785.4

### OPERATING INSTRUCTIONS

1. Tighten air motor chuck onto mixer shaft securely.
2. The mixer should be immersed in material to be mixed before turning on power, and kept immersed while in motion.
3. Hold unit firmly—keep under rigid control. If the container is of a small size, or the material highly viscous, the container should be anchored or otherwise held in place container from being thrown or overturned.

### WARNING

Do not use electric drill with flammable materials.

### MIXING OF MATERIALS

1. Prepared, packaged stock materials, such as paints or other coatings, with powders or pigments may settle to the bottom of container. Submerge mixer to bottom of container and start air motor. Move unit slowly around container until these solids have been released and are mixed.
2. For mixing two or more materials, such as a catalyst or hardener—use the above procedure. Pour the catalyst into container as close to mixer shaft as possible for thorough blending. Speed may be changes to suit viscosity of materials to be worked.
3. Dry powders, such as adhesives, joint compounds, mud, grout, etc., should be mixed as stated above in 2. Mixer speed should be reduced until all dry powder is added to liquid, then unit speed may be increased.
4. Coloring or tinting of materials. Same as 2 above.
5. Cleaning unit. Immerse in compatible solvent and turn unit on for approximately 30 to 60 seconds.

### NOTE

If material reaches a degree of turbulence which forces it out of container, the speed should be reduced or the unit "triggered".

### WARNING

ON NO ACCOUNT SHOULD THIS PRODUCT BE USED WITH FLAMMABLE MATERIALS.

## BINKS MODEL 83-1922 AIR MOTOR ASSEMBLY

**SPEED** – The speed of the air motor is regulated by the air adjusting valve (19) (see page 1). The speed of the propeller shaft is determined by the fluid, but it should never exceed 3,000 RPM.

**AIR SUPPLY** – The air supply to the motor should be 60 PSI, minimum, for best results.

**LUBRICATION** – Air motor – the bearings are pre-lubricated and sealed. However, every 100 hours, insert a few drops of SAE 10 non-detergent oil into the air inlet to lubricate the vanes and housing surfaces.

## WARRANTY POLICY

This product is covered by Binks' materials and workmanship limited warranty.

The use of parts or accessories from sources other than Binks will void all warranties. Failure to follow reasonable maintenance guidance provided can invalidate the warranty.

For specific warranty information, please contact Binks.

For technical assistance or to locate an authorized distributor, contact one of our international sales and customer support locations listed below.

REGION	BINKS CONTACT	WARRANTY PAGE
Americas	Tel: 1-800-992-4657	
Europe, Africa, Middle East	Tel: +4401202571111	
India	marketingroa@binks.com	
China	Tel: +862133730108	
Korea	Tel: +82313663303	
Japan	Tel: +81457856421	
Australia	Tel: +61085257555	

For additional information or copies of your service manual, please visit us online at:

[binks.com/en/library](https://binks.com/en/library)

Or use this QR code with your mobile device:



Obey local or municipal regulations for product recycling and disposal.

# Binks®

Binks is a global leader in innovative finishing technologies.  
Binks reserves the right to modify equipment specifications without prior notice.  
Binks®, DeVilbiss® and Ransburg® are registered trademarks of Binks US, LLC.